

2948

11063

20077

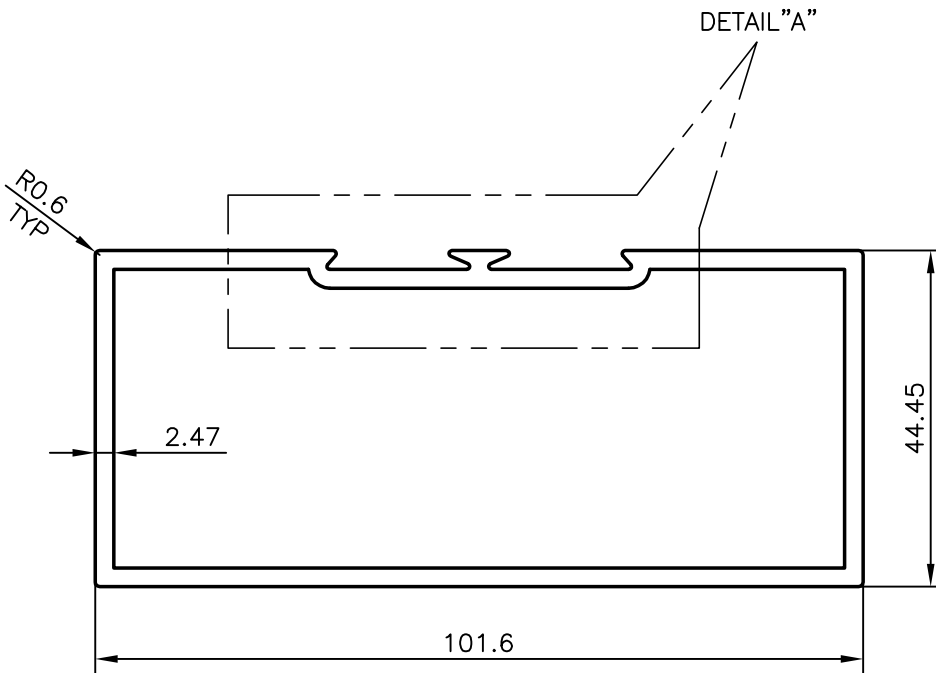
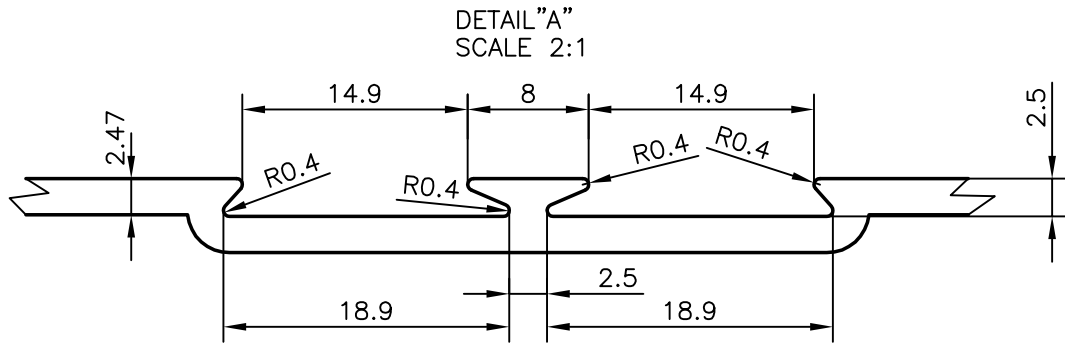

GENERAL WALL THICKNESS :- 2.47 mm.

NO. OF PIECES IN 100 kgs = 14 (AVERAGE)



SYMBOL OF QUALITY
AN ISO 9001 COMPANY

JINDAL ALUMINIUM LTD.
BANGALORE-560073 (INDIA)

	NAME	DATE
DRAWN	RAGHAVENDRA	13-09-2006
CHECKED		
APPROVED		

1. ALL DIMENSIONS ARE IN mm.
2. ROUND OFF ALL SHARP CORNERS WITH 0.40 mm.
3. TOLERANCES WILL BE AS PER IS:6477-1983 UNLESS OTHERWISE SPECIFIED

SCALE	1:1
AREA mm ²	721.845
PERIMETER mm.	311.988
WEIGHT kg/m	1.950

PARTY'S NAME	-	DRAWING No.	2948	SECTION No.	2948
PARTY'S DRAWING No.	LIGHTER SECTION OF 4617		11063		11063
ALLOY & TEMPER	HE9 WP		20077		20077
DESCRIPTION	PARTITION SECTION				