

2949

11065

20078

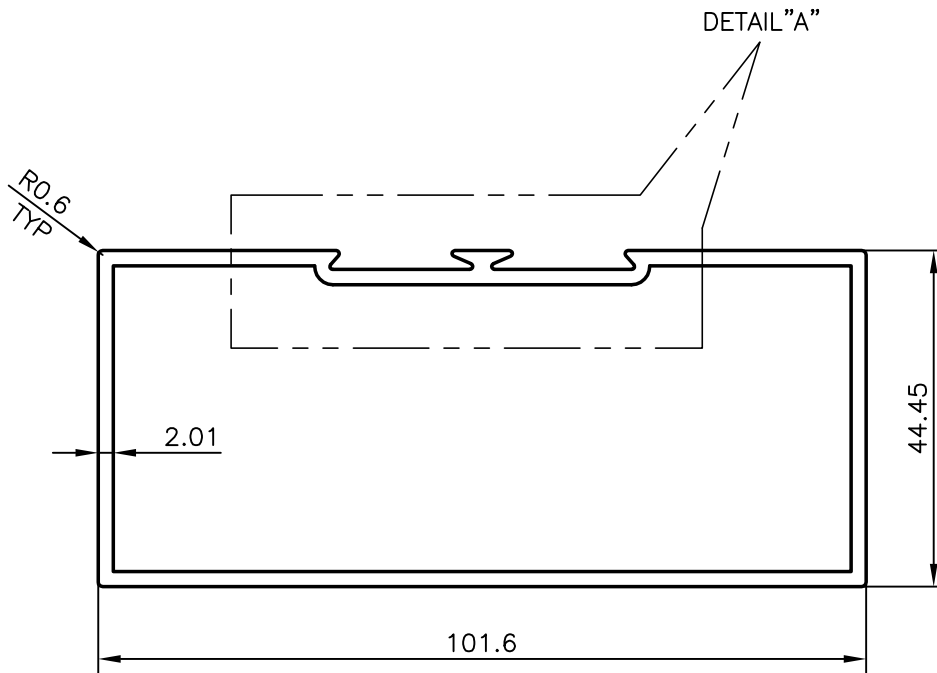
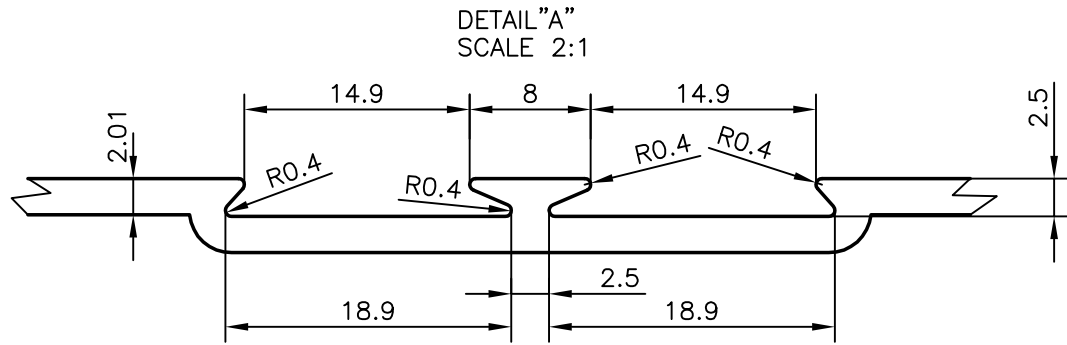

GENERAL WALL THICKNESS :- 2.01 mm.

NO. OF PIECES IN 100 kgs = 17 (AVERAGE)



SYMBOL OF QUALITY
AN ISO 9001 COMPANY

JINDAL ALUMINIUM LTD.
BANGALORE-560073 (INDIA)

	NAME	DATE
DRAWN	RAGHAVENDRA	13-09-2006
CHECKED		
APPROVED		

1. ALL DIMENSIONS ARE IN mm.
2. ROUND OFF ALL SHARP CORNERS WITH 0.40 mm.
3. TOLERANCES WILL BE AS PER IS:6477-1983 UNLESS OTHERWISE SPECIFIED

SCALE	1:1
AREA mm ²	594.459
PERIMETER mm.	311.988
WEIGHT kg/m	1.605

PARTY'S NAME	-	DRAWING No.	2949	SECTION No.	2949
PARTY'S DRAWING No.	LIGHTER SECTION OF 4617		11065		11065
ALLOY & TEMPER	HE9 WP		20078		20078
DESCRIPTION	PARTITION SECTION				