

P-3626-1

2952

11004

20080

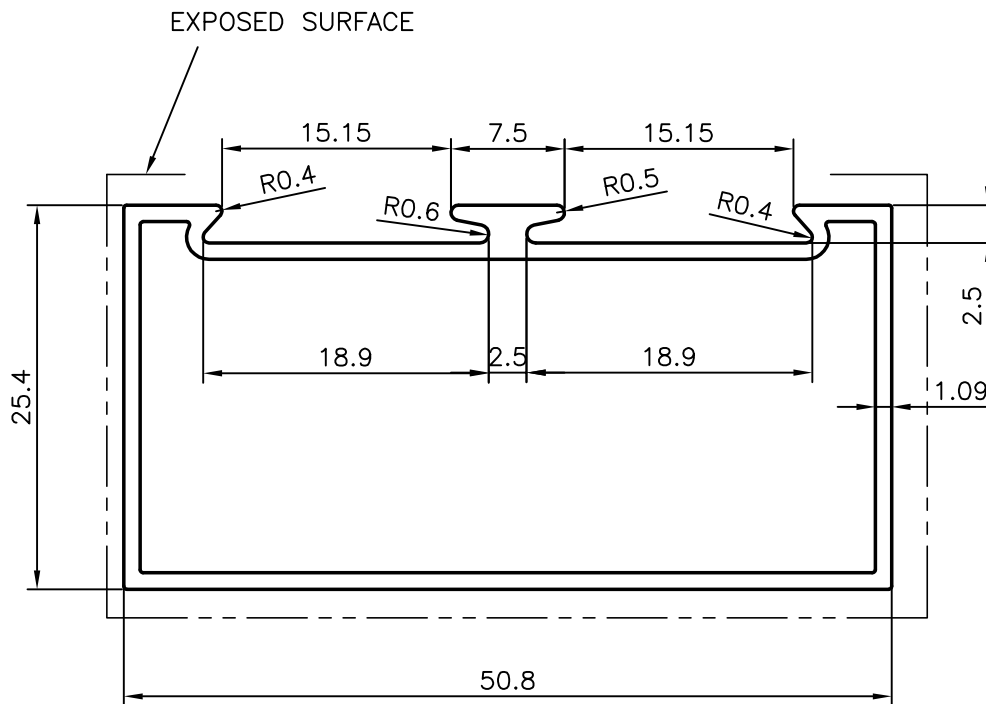

GENERAL WALL THICKNESS:- 1.09 mm.



SYMBOL OF QUALITY
AN ISO 9001 COMPANY

JINDAL ALUMINIUM LTD.
BANGALORE-560073 (INDIA)

	NAME	DATE
DRAWN	PRASHANT	04-11-2006
CHECKED		
APPROVED		
SCALE		2:1
AREA mm ²		180.919
PERIMETER mm.		172.344
WEIGHT kg/m		0.489
DRAWING No.	SECTION No.	
P-3621-1	-	
2952	2952	
11004	11004	
20080	20080	

1. ALL DIMENSIONS ARE IN mm.
2. ROUND OFF ALL SHARP CORNERS WITH 0.40 mm.
3. TOLERANCES WILL BE AS PER IS:6477-1983 UNLESS OTHERWISE SPECIFIED

PARTY'S NAME	GENERAL CATEGORY,. COCHIN MARKET
PARTY'S DRAWING No.	AS PER SPECIFICATION
ALLOY & TEMPER	HE9 WP
DESCRIPTION	PARTITION SECTION SINGLE GROOVE