

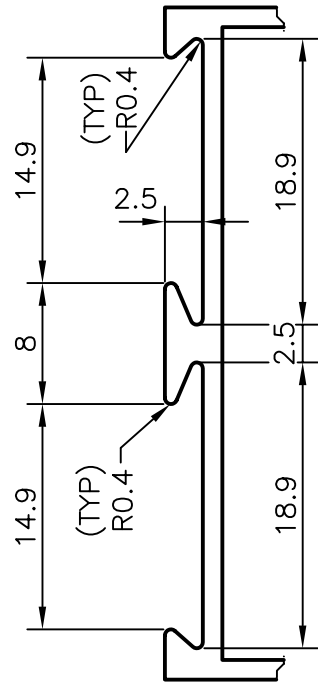

S561
2965
20086

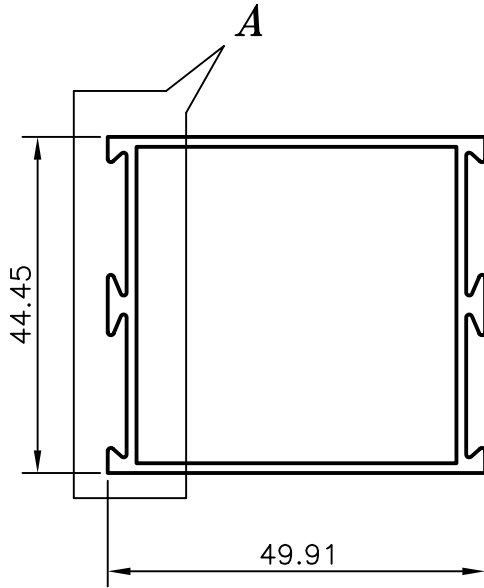

DETAIL AT 'A'
(2:1)

1. GENERAL WALL THICKNESS :- 1.30 mm.

| | | | | |
|--|--|----------------------|------------|------------|
|  SYMBOL OF QUALITY AN ISO 9002 COMPANY | JINDAL ALUMINIUM LTD. BANGALORE-560073 (INDIA) | | NAME | DATE |
| | | DRAWN | R.D.Sharma | 06-08-2000 |
| 1. ALL DIMENSIONS ARE IN mm. 2. ROUND OFF ALL SHARP CORNERS WITH 0.40 mm. 3. TOLERANCES WILL BE AS PER IS 6477-1983 UNLESS OTHERWISE SPECIFIED | | CHECKED | | |
| | | APPROVED | | |
| | | SCALE | 1:1 | |
| PARTY'S NAME | RADHA SOAMI SATSANG BEAS, BEAS | WEIGHT kg/m | 0.753 | |
| PARTY'S DRAWING No. | BM-20028 | SECTION No. | 20086 | |
| ALLOY & TEMPER | HE9 WP | DRAWING No. 20086 | | |
| DESCRIPTION | PARTITION SECTION | | | |