

P-2877
S559
2966
20087

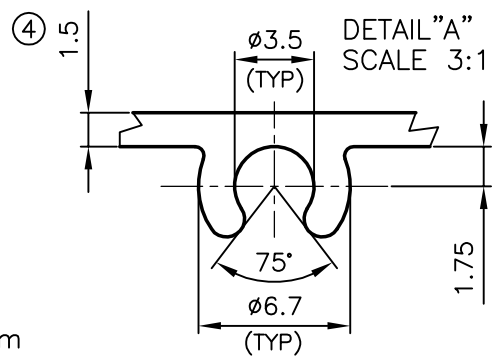

GENERAL WALL THICKNESS = 1.50mm
 F = FULL RADIUS (8 PLACES)

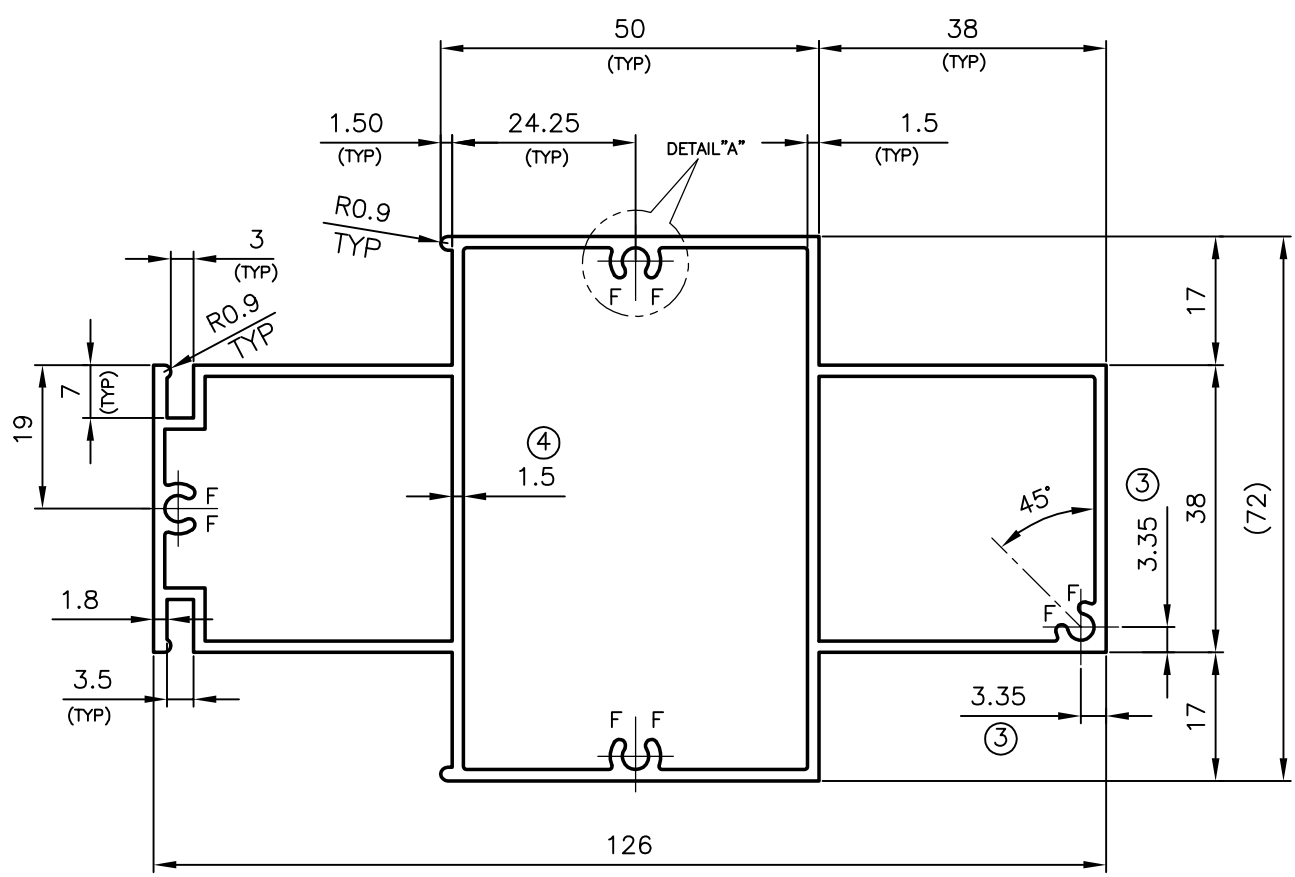

ISSUE-4 WALL THICKNESS CHANGED FROM 1.6 TO 1.5mm WEIGHT ALSO CHANGED FROM 2.197kg/M TO 2.079kg/M AS PER PARTY'S REQUIREMENT

ISSUE-3 CENTRE RIBS ADDED, WALL THICKNESS CHANGED FROM 1.8 TO 1.6mm DIMENSION CHANGED FROM 3.55 TO 3.35mm WEIGHT ALSO CHANGED FROM 2.120kg/M TO 2.197kg/M

 SYMBOL OF QUALITY AN ISO 9001 COMPANY	JINDAL ALUMINIUM LTD. BANGALORE-560073 (INDIA)	DRAWN	NAME	DATE
		CHECKED	RAGHAVENDRA	21-11-2008
1. ALL DIMENSIONS ARE IN mm. 2. ROUND OFF ALL SHARP CORNERS WITH 0.40 mm. 3. TOLERANCES WILL BE AS PER IS:6477-1983 UNLESS OTHERWISE SPECIFIED		APPROVED		
		SCALE		1:1
PARTY'S NAME RADHA SOAMI SATSANG BEAS, BEAS		AREA	mm ²	770.062
		PERIMETER	mm.	429.068
PARTY'S DRAWING No. BM-20009 & AS PER REQUIREMENT		WEIGHT	kg/m	2.079
		DRAWING No.		SECTION No.
ALLOY & TEMPER HE9 WP		P-2877		-
		S559		S559
DESCRIPTION WINDOW CENTRE MULLION		2966		2966
		20087		20087-ISSUE-4