

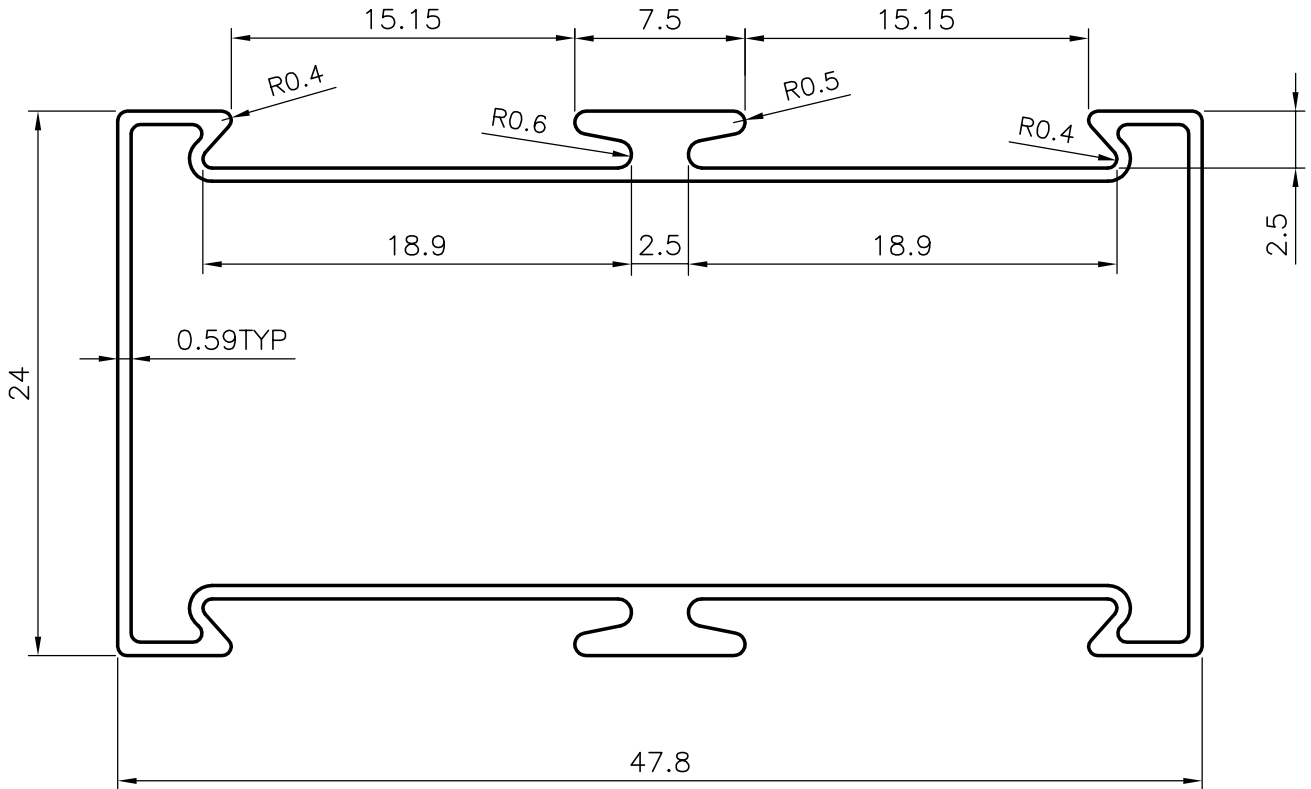

P-4077
2968
20089

EXPOSED SURFACE

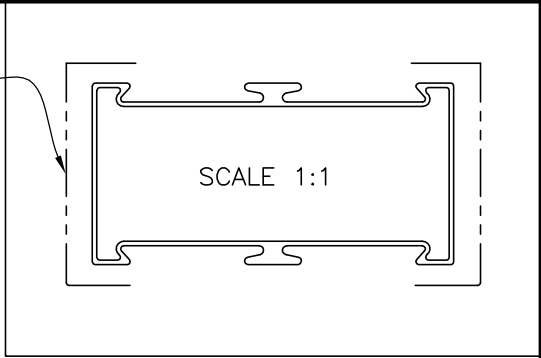

GENERAL WALL THICKNESS = 0.59mm

3658 mm, LONG PIECES IN 100 Kgs = 087 (AVERAGE)

 SYMBOL OF QUALITY AN ISO 9002 COMPANY	JINDAL ALUMINIUM LTD. BANGALORE-560073 (INDIA)	NAME		DATE
		DRAWN	RAGHAVENDRA	20-02-2004
1. ALL DIMENSIONS ARE IN mm. 2. ROUND OFF ALL SHARP CORNERS WITH 0.40 mm. 3. TOLERANCES WILL BE AS PER IS:6477-1983 UNLESS OTHERWISE SPECIFIED		CHECKED		
		APPROVED		
PARTY'S NAME GENERAL CATEGORY ,, COCHIN MARKET		SCALE		3:1
		AREA mm ²		117.114
PARTY'S DRAWING No. AS PER SAMPLE		PERIMETER mm.		183.487
		WEIGHT kg/m		0.316
ALLOY & TEMPER HE9 WP		DRAWING No.		SECTION No.
		P-4077		-
DESCRIPTION PARTITION SECTION (DOUBLE GROOVE)		2968		2968-ISSUE-2
		20089		20089