

P-3376-2
 X189
 2977
 20093

DETAIL "B"
 SCALE 2;1

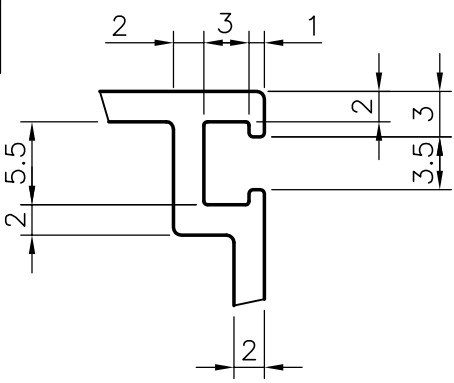

DETAIL "A"
 SCALE 2:1

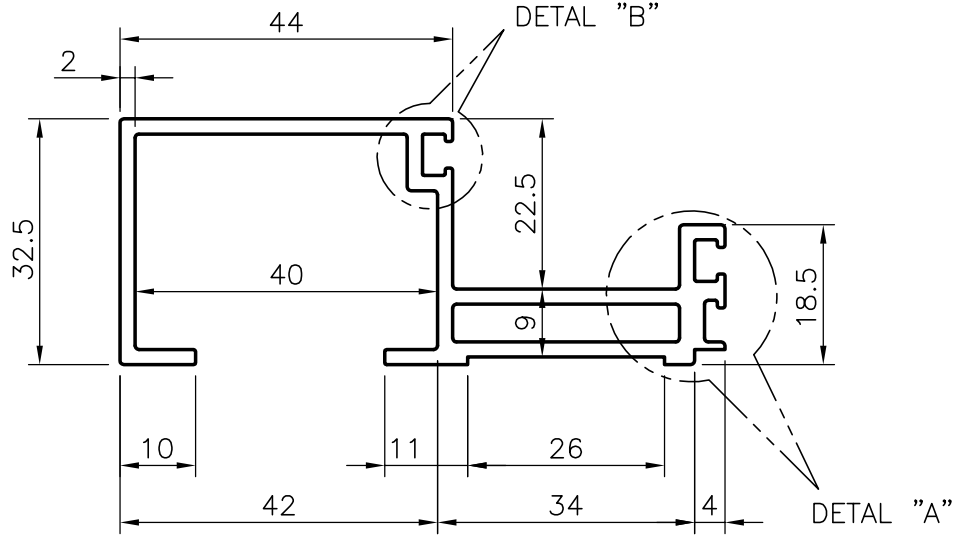
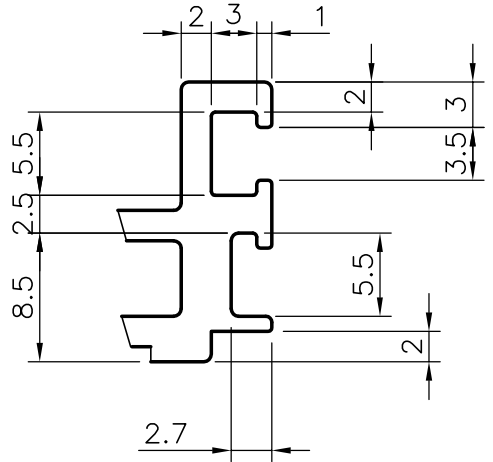

GENERAL WALL THICKNESS = 2.0 mm

 SYMBOL OF QUALITY AN ISO 9002 COMPANY	JINDAL ALUMINIUM LTD. BANGALORE-560073 (INDIA)		NAME	DATE
		DRAWN	RAGHAVENDRA	28-07-01
		CHECKED		
1. ALL DIMENSIONS ARE IN mm. 2. ROUND OFF ALL SHARP CORNERS WITH 0.40 mm. 3. TOLERANCES WILL BE AS PER I.S: 6477-1983 UNLESS OTHERWISE SPECIFIED		APPROVED		
		SCALE	1:1 & 2:1	
		WEIGHT kg/m	1.197	
PARTY'S NAME	ALMECH INDUSTRIES ,. MUMBAI	PERIMETER	360.28mm	
PARTY'S DRAWING No.	AS PER SKETCH	SECTION No.	20093	
ALLOY & TEMPER	HE9 WP	DRAWING No.	20093	
DESCRIPTION	-			