

P-5884

S1604

20123

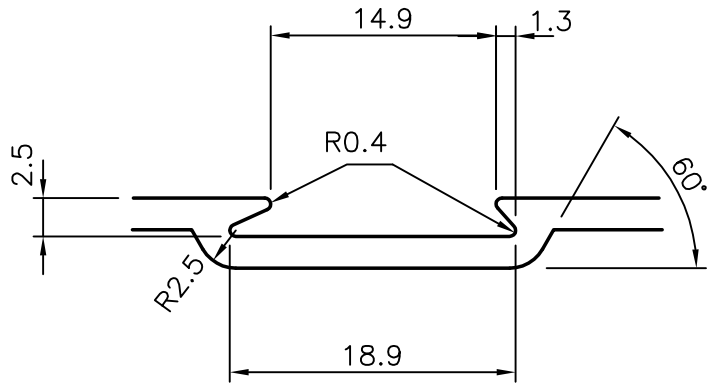

**DETAIL AT "A"**

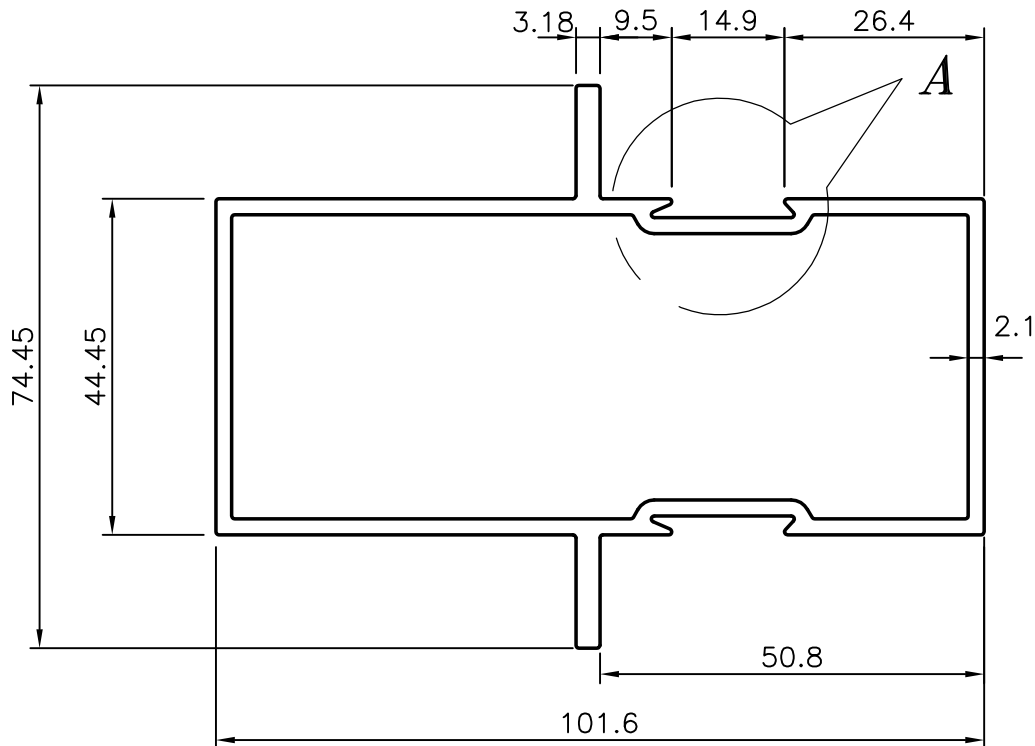

GENERAL WALL THICKNESS = 2.1 mm



SYMBOL OF QUALITY  
AN ISO 9001 COMPANY

**JINDAL ALUMINIUM LTD.**  
BANGALORE-560073 (INDIA)

	NAME	DATE
DRAWN	J.P.KAUSHIK	21-09-2005
CHECKED		
APPROVED		

1. ALL DIMENSIONS ARE IN mm.
2. ROUND OFF ALL SHARP CORNERS WITH 0.40 mm.
3. TOLERANCES WILL BE AS PER IS:3965-1981 UNLESS OTHERWISE SPECIFIED

SCALE	1:1
AREA mm <sup>2</sup>	719.49
PERIMETER mm.	370.933
WEIGHT kg/m	1.943

PARTY'S NAME	P.L.RAJU CONSTRUCTION LIMITED., HYDERABAD
PARTY'S DRAWING No.	AS PER SPECIFICATION
ALLOY & TEMPER	HE9 WP
DESCRIPTION	PARTITION SECTION

DRAWING No.	SECTION No.
P-5884	-
S1604	S1604
20123	20123