

P-6315

20125

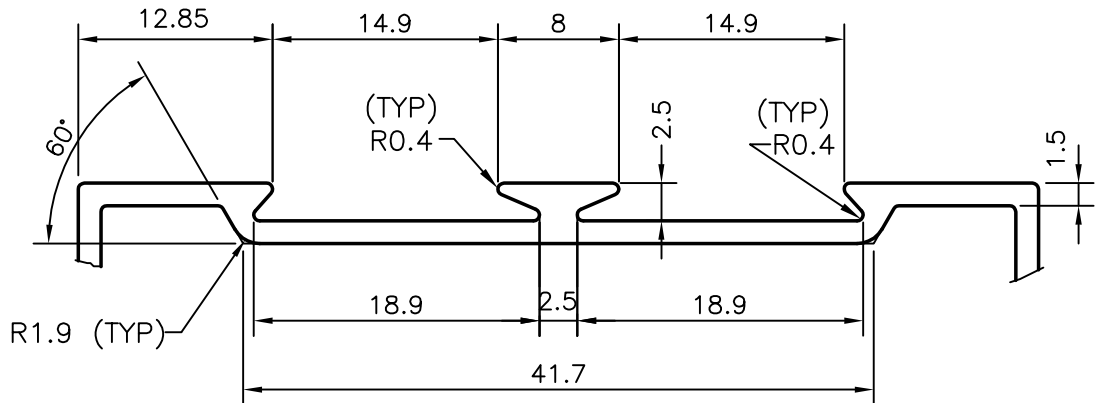

**DETAIL "A"**

(2:1)

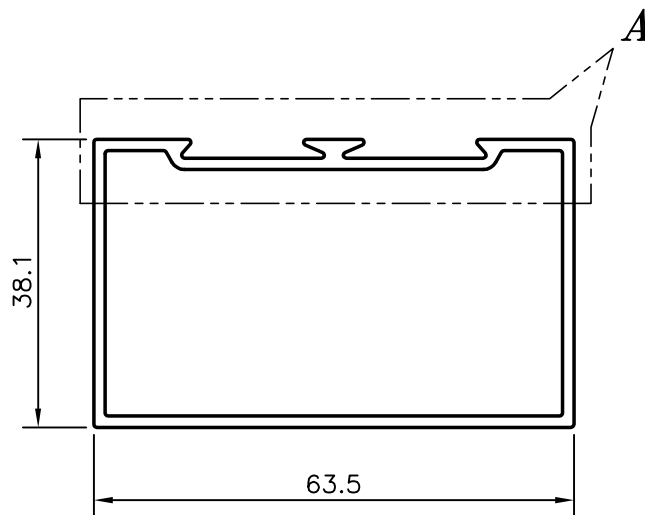

GENERAL WALL THICKNESS :- 1.50 mm.



SYMBOL OF QUALITY  
AN ISO 9001 COMPANY

**JINDAL ALUMINIUM LTD.**  
**BANGALORE-560073 (INDIA)**

	NAME	DATE
DRAWN	J.P.KAUSHIK	11-04-2006
CHECKED		
APPROVED		
SCALE		1:1
AREA mm <sup>2</sup>		318.788
PERIMETER mm.		223.431
WEIGHT kg/m		0.861
DRAWING No.	SECTION No.	
P-6315	-	
20125	20125	

1. ALL DIMENSIONS ARE IN mm.
2. ROUND OFF ALL SHARP CORNERS WITH 0.40 mm.
3. TOLERANCES WILL BE AS PER IS:6477-1983 UNLESS OTHERWISE SPECIFIED

PARTY'S NAME	GENERAL CATEGORY. CHENNAI MARKET
PARTY'S DRAWING No.	HEAVIER OF SECTION No 20063
ALLOY & TEMPER	HE9 WP
DESCRIPTION	PARTITION SECTION - SINGLE