

P-9738-2

S2435

20131

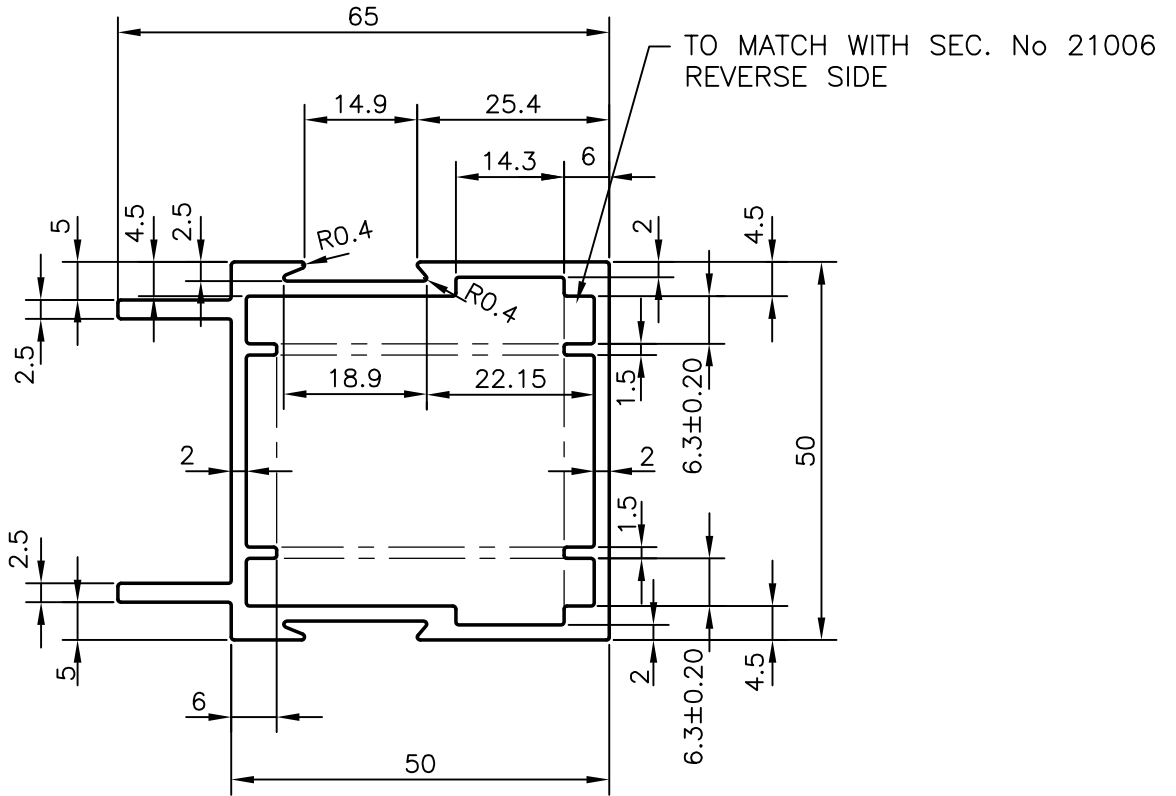
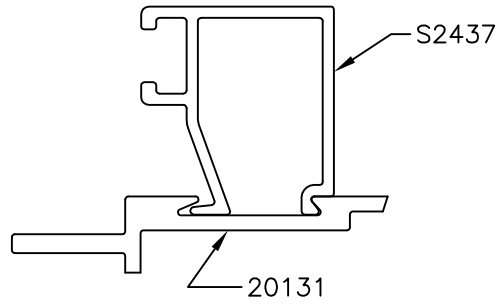

SYMBOL OF QUALITY  
AN ISO 9001 COMPANY

**JINDAL ALUMINIUM LTD.**  
BANGALORE-560073 (INDIA)

	NAME	DATE
DRAWN	J.P.KAUSHIK	20-01-2010
CHECKED		
APPROVED		

1. ALL DIMENSIONS ARE IN mm.
2. ROUND OFF ALL SHARP CORNERS WITH 0.40 mm.
3. TOLERANCES WILL BE AS PER IS:6477-1983, UNLESS OTHERWISE SPECIFIED

SCALE	1:1
AREA mm <sup>2</sup>	557
PERIMETER mm.	278.858
WEIGHT kg/m	1.504

PARTY'S NAME	GSC GLASS PVT. LTD., NOIDA
PARTY'S DRAWING No.	M6002
ALLOY & TEMPER	HE9 WP
DESCRIPTION	MISC. SECTION HOLLOW

DRAWING No.	SECTION No.
P-9738-2	-
S2435	S2435
20131	20131