

P-11254-2

S3066

20135

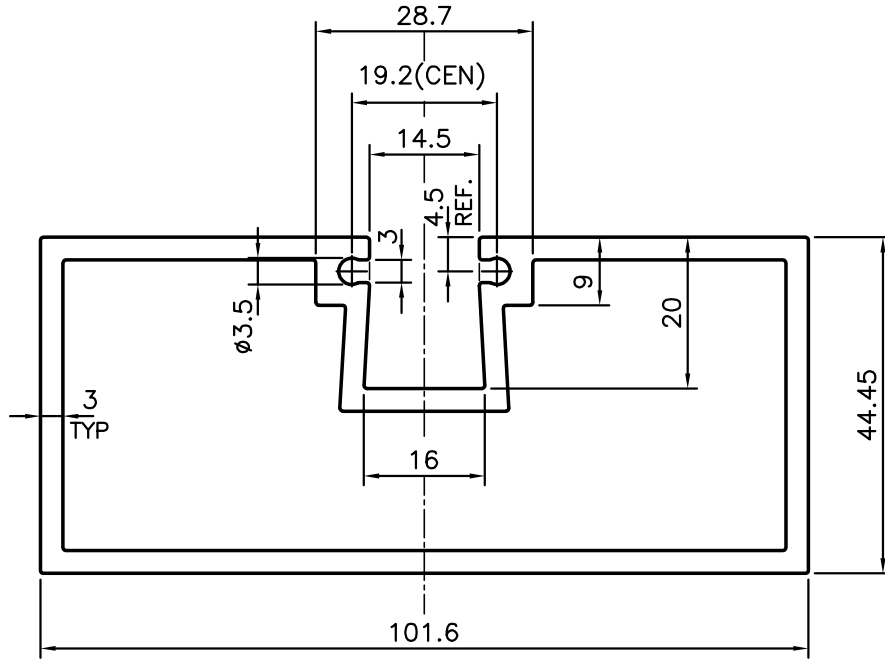

SYMBOL OF QUALITY
AN ISO 9001 COMPANY

JINDAL ALUMINIUM LTD.
BANGALORE-560073 (INDIA)

	NAME	DATE
DRAWN	J.P.KAUSHIK	04-10-2011
CHECKED		
APPROVED	S.S.GARG	04-10-2011
SCALE		1:1
AREA mm ²		989.945
PERIMETER mm.		346.142
WEIGHT kg/m		2.673
DRAWING No.	SECTION No.	
P-11254-2	-	
S3066	S3066	
20135	20135	

1. ALL DIMENSIONS ARE IN mm.
2. ROUND OFF ALL SHARP CORNERS WITH 0.40 mm.
3. TOLERANCES WILL BE AS PER BS:EN-755-9 UNLESS OTHERWISE SPECIFIED

PARTY'S NAME	CHANDRALEKHA CONSTRUCTION PVT. LTD.,DELHI
PARTY'S DRAWING No.	AS PER 20018 (MODIFIED)
ALLOY & TEMPER	HE9 WP
DESCRIPTION	PARTITION SECTION