

P-11342

S3122

20136

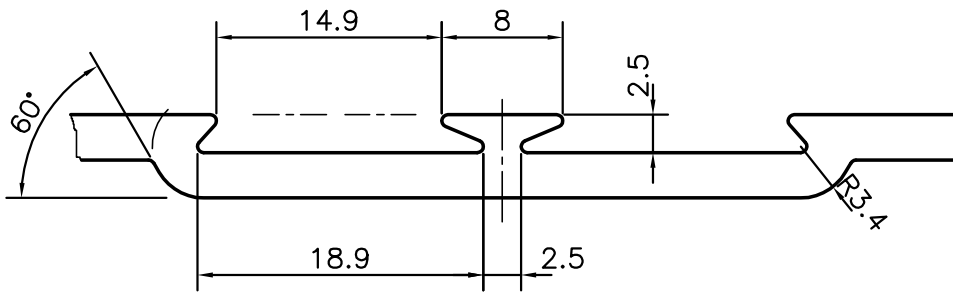

DETAIL OF 'A'
SCALE 2:1

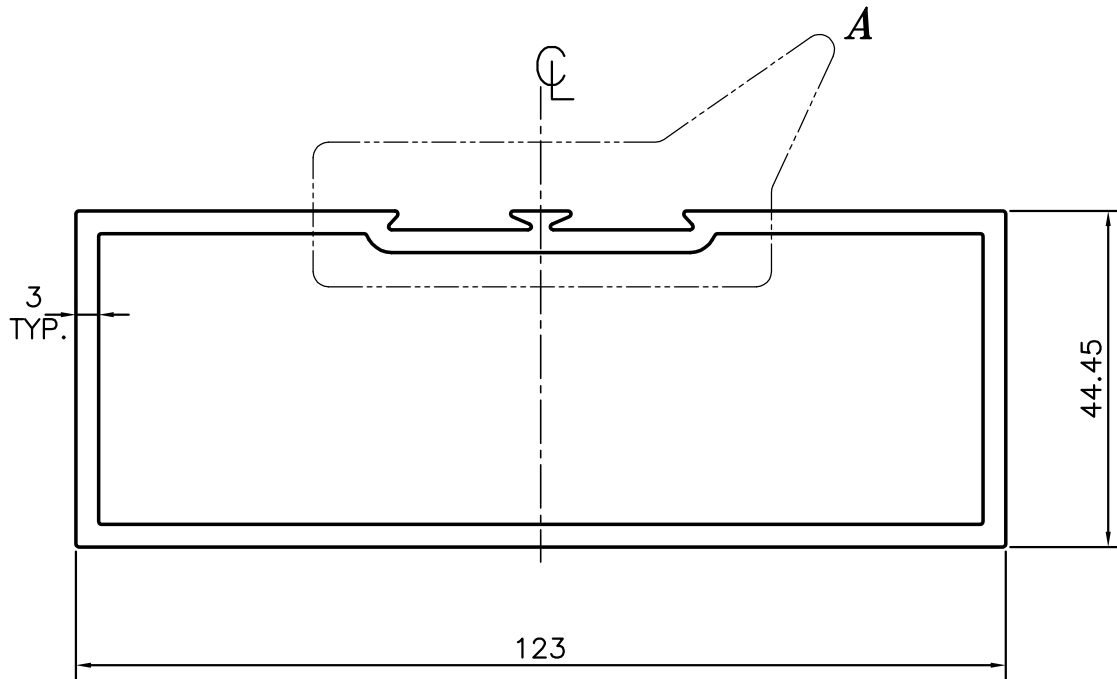

SYMBOL OF QUALITY
AN ISO 9001 COMPANY

JINDAL ALUMINIUM LTD.
BANGALORE-560073 (INDIA)

	NAME	DATE
DRAWN	PARVESH	24-11-2011
CHECKED		
APPROVED	S.S.GARG	08-12-2011
SCALE		1:1
AREA mm ²		995.148
PERIMETER mm.		355.131
WEIGHT kg/m		2.687
DRAWING No.	SECTION No.	
P-11342	-	
S3122	S3122	
20136	20136	

1. ALL DIMENSIONS ARE IN mm.
2. ROUND OFF ALL SHARP CORNERS WITH 0.40 mm.
3. TOLERANCES WILL BE AS PER, IS:6477-1983 UNLESS OTHERWISE SPECIFIED

PARTY'S NAME	GLAZE TECNO INDIA, MUMBAI
PARTY'S DRAWING No.	HEAVIER OF SECTION No. 20059
ALLOY & TEMPER	HE9 WP
DESCRIPTION	PARTITION SECTION