

P-13602

20144

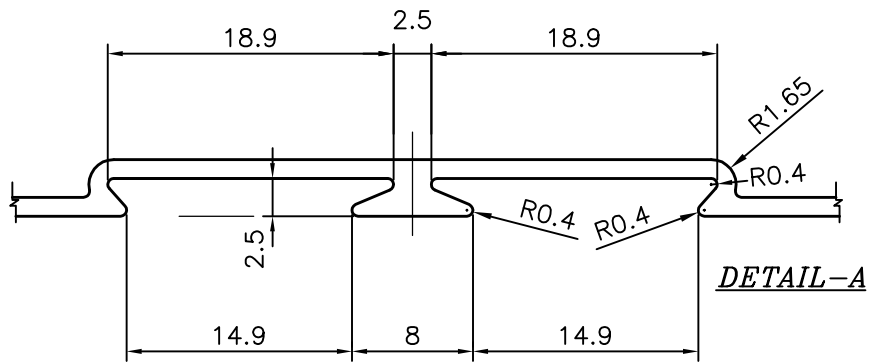

*= 0.5 RADIUS (8 PLACES)

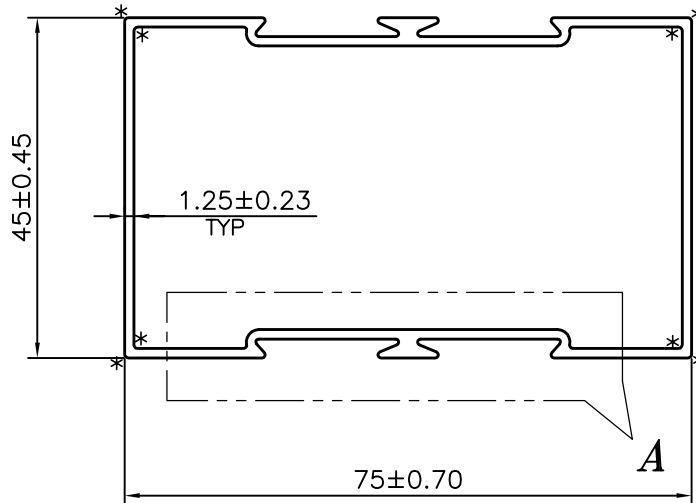

SYMBOL OF QUALITY
AN ISO 9002 COMPANY

JINDAL ALUMINIUM LTD.
BANGALORE-560073 (INDIA)

	NAME	DATE
DRAWN	J.P.KAUSHIK	23-05-2014
CHECKED		
APPROVED	S.S.GARG	24-09-2014
SCALE		1:1
AREA mm ²		336.415
PERIMETER mm.		280.977
WEIGHT kg/m		0.908
DRAWING No.	SECTION No.	
P-13602	-	
20144	20144	

1. ALL DIMENSIONS ARE IN mm.
2. ROUND OFF ALL SHARP CORNERS WITH 0.40 mm.
3. TOLERANCES WILL BE AS PER IS:6477-1983 UNLESS OTHERWISE SPECIFIED

PARTY'S NAME	GENERAL CATEGORY, (BANGALORE MARKET)
PARTY'S DRAWING No.	AS PER DRAWING
ALLOY & TEMPER	HE9 WP
DESCRIPTION	PARTITION SECTION