

P-12586

S3693

20148

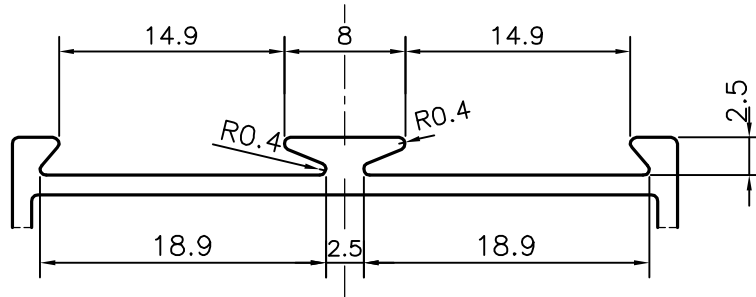

DETAIL OF "A"
SCALE 2:1

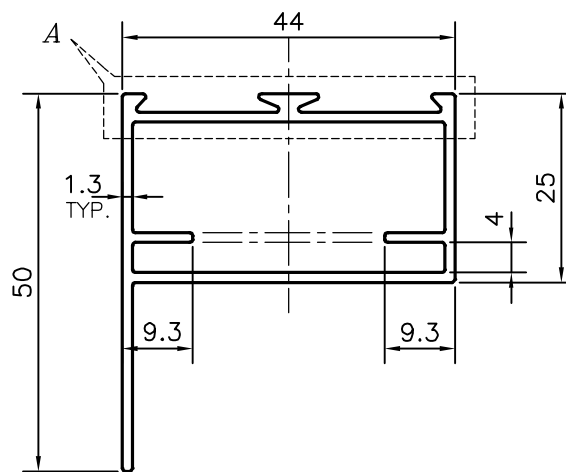

SYMBOL OF QUALITY
AN ISO 9001 COMPANY

JINDAL ALUMINIUM LTD.
BANGALORE-560073 (INDIA)

	NAME	DATE
DRAWN	PARVESH	06-03-2013
CHECKED		
APPROVED	S.S.GARG	14-03-2013
SCALE		1:1
AREA mm ²		244.94
PERIMETER mm.		207.888
WEIGHT kg/m		0.661
DRAWING No.	SECTION No.	
P-12586	-	
S3693	S3693	
20148	20148	

1. ALL DIMENSIONS ARE IN mm.
2. ROUND OFF ALL SHARP CORNERS WITH 0.40 mm.
3. TOLERANCES WILL BE AS PER IS:6477-1983 UNLESS OTHERWISE SPECIFIED

PARTY'S NAME	INNOVATIVE INFRA PROJECTS, BANGALORE
PARTY'S DRAWING No.	AS PER DRWING
ALLOY & TEMPER	HE9 WP
DESCRIPTION	PARTITION SECTION