

P-10904-1

S2966

20154

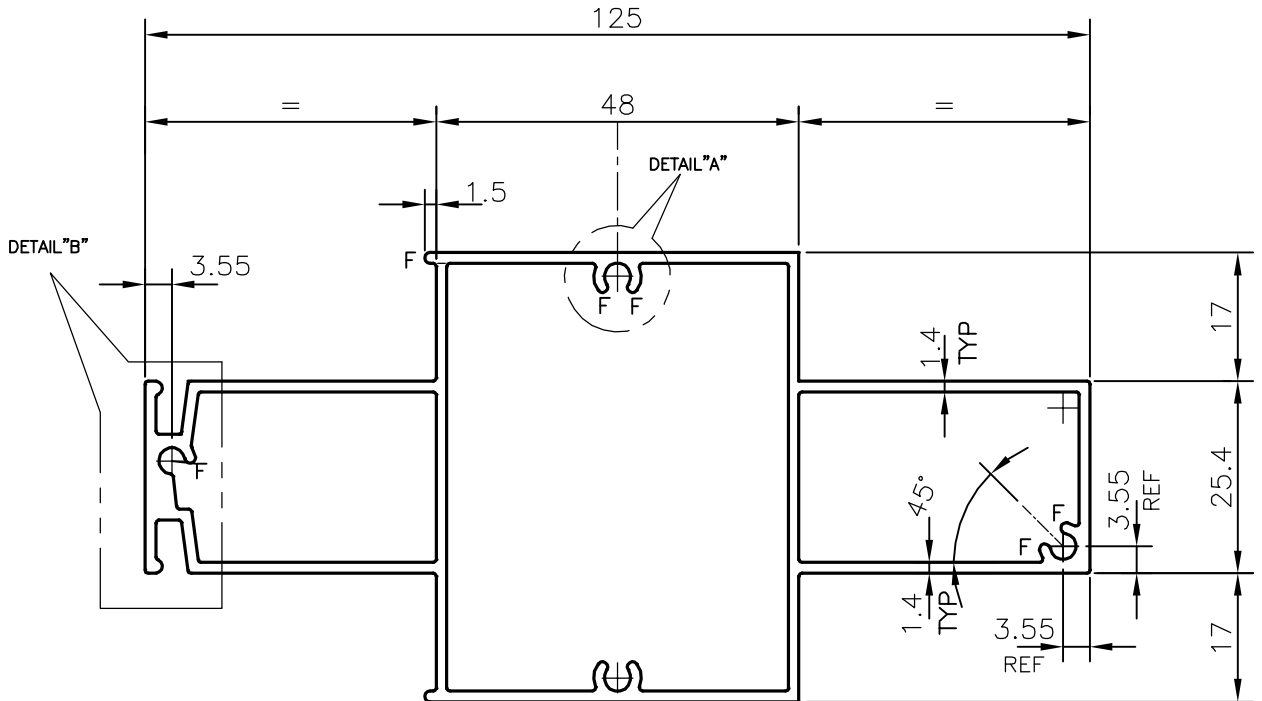
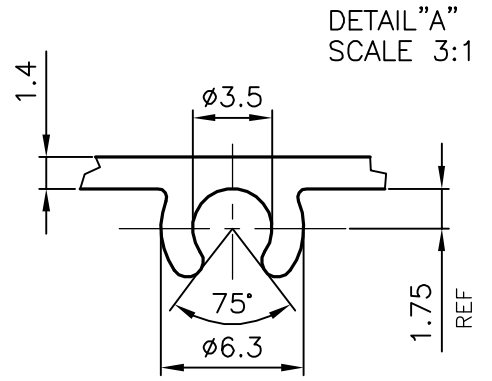
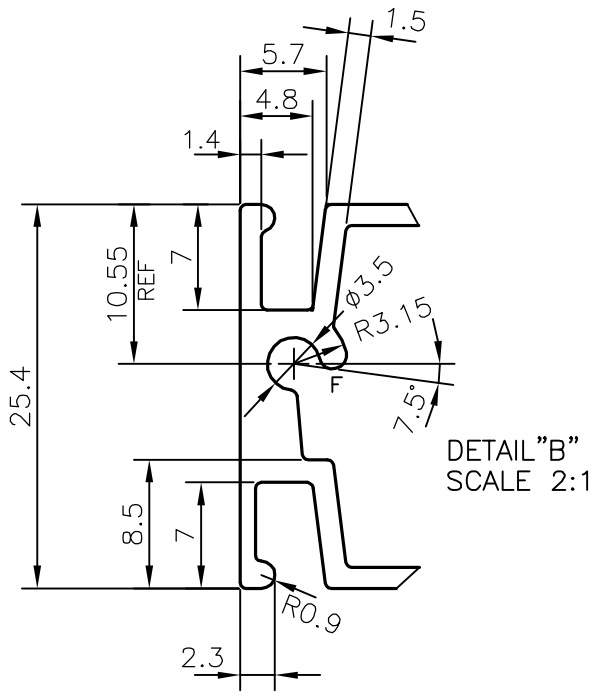

SYMBOL OF QUALITY
AN ISO 9001 COMPANY

JINDAL ALUMINIUM LTD.
BANGALORE-560073 (INDIA)

	NAME	DATE
DRAWN	J.P.KAUSHIK	07-05-2011
CHECKED		
APPROVED	S.S.GARG	09-06-2011

1. ALL DIMENSIONS ARE IN mm.
2. ROUND OFF ALL SHARP CORNERS WITH 0.40 mm.
3. TOLERANCES WILL BE AS PER IS:6477-1983 UNLESS OTHERWISE SPECIFIED

SCALE	1:1
AREA mm ²	650.728
PERIMETER mm.	399.343
WEIGHT kg/m	1.757

PARTY'S NAME DG-MAP, NEW DELHI

PARTY'S DRAWING No. DGM-14

ALLOY & TEMPER HE9 WP

DESCRIPTION MULLION SECTION

DRAWING No.	SECTION No.
-------------	-------------

P-10904-1	-
-----------	---

S2966	S2966
-------	-------

20154	20154
-------	-------