

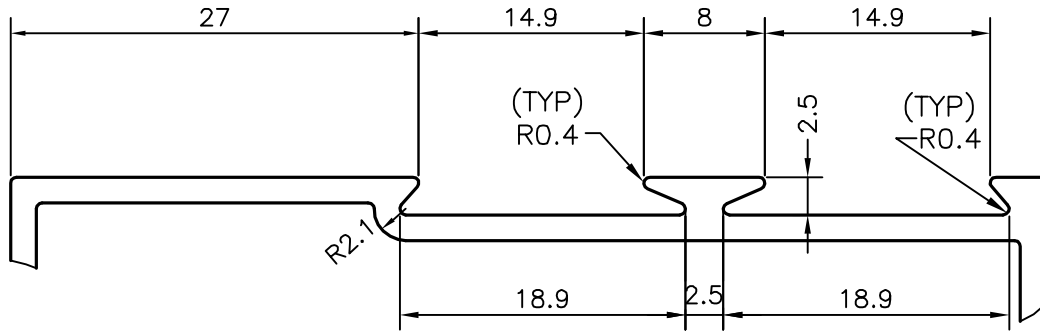

P-15827
20156

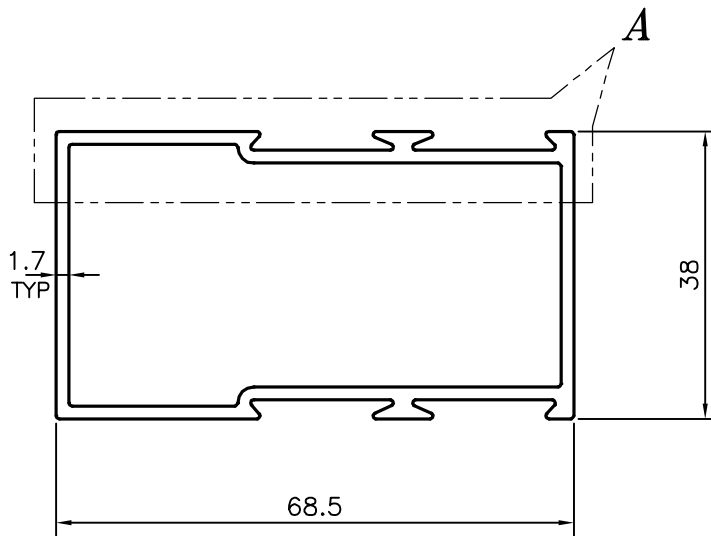

DETAIL "A"
(2:1)



 SYMBOL OF QUALITY AN ISO 9001 COMPANY	JINDAL ALUMINIUM LTD. BANGALORE-560073 (INDIA)	DRAWN	J.P.KAUSHIK	DATE	04-05-2016
		CHECKED			
1. ALL DIMENSIONS ARE IN mm. 2. ROUND OFF ALL SHARP CORNERS WITH 0.40 mm. 3. TOLERANCES WILL BE AS PER IS:6477-1983 UNLESS OTHERWISE SPECIFIED		APPROVED	S.S. GARG		13-05-2016
		SCALE			1:1
PARTY'S NAME GENERAL CATEGORY, DELHI MARKET		AREA mm ²			393.466
		PERIMETER mm.			254.149
ISSUE No. AS PER DRAWING		WEIGHT kg/m			1.062
		DRAWING No.	P-15827	SECTION No.	-
ALLOY & TEMPER HE9 WP			20156		20156
DESCRIPTION PARTITION SECTION-DOUBLE					