

P-15100

S4628

20160

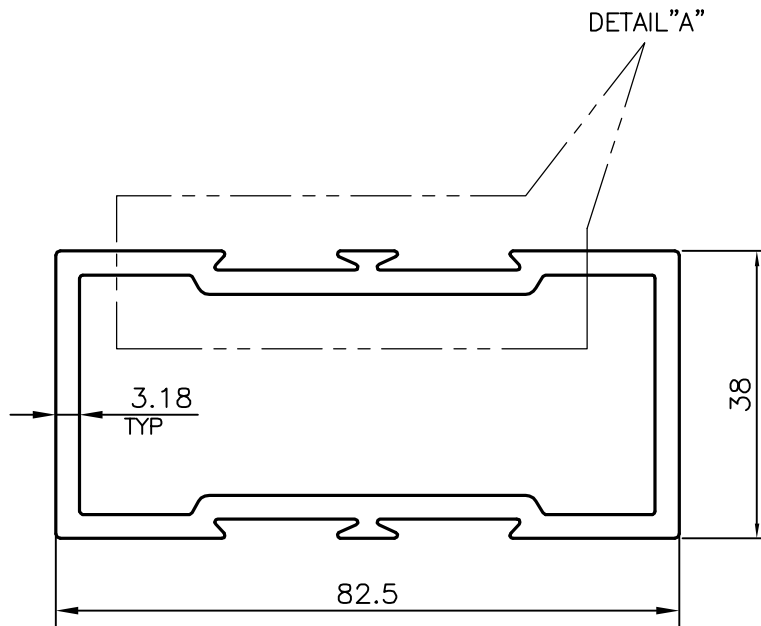
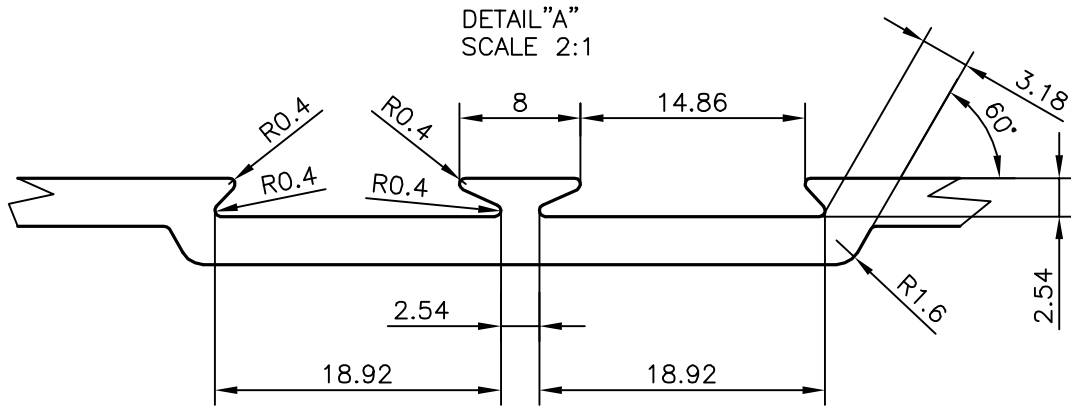

GENERAL WALL THICKNESS :- 3.18 mm.



SYMBOL OF QUALITY
AN ISO 9001 COMPANY

JINDAL ALUMINIUM LTD.
BANGALORE-560073 (INDIA)

	NAME	DATE
DRAWN	J.P.KAUSHIK	31-08-2015
CHECKED		
APPROVED	S.S.GARG	03-09-2015
SCALE		1:1
AREA mm ²		783.156
PERIMETER mm.		282.37
WEIGHT kg/m		2.115
DRAWING No.	SECTION No.	
P-15100	-	
S4628	S4628	
20160	20160	

1. ALL DIMENSIONS ARE IN mm.
2. ROUND OFF ALL SHARP CORNERS WITH 0.40 mm.
3. TOLERANCES WILL BE AS PER IS:6477-1983 UNLESS OTHERWISE SPECIFIED

PARTY'S NAME	SAM INDIA BUILTWEILL PVT. LTD., DELHI
PARTY'S DRAWING No.	AS PER SKETCH
ALLOY & TEMPER	HE9 WP
DESCRIPTION	PARTITION SECTION DOUBLE