

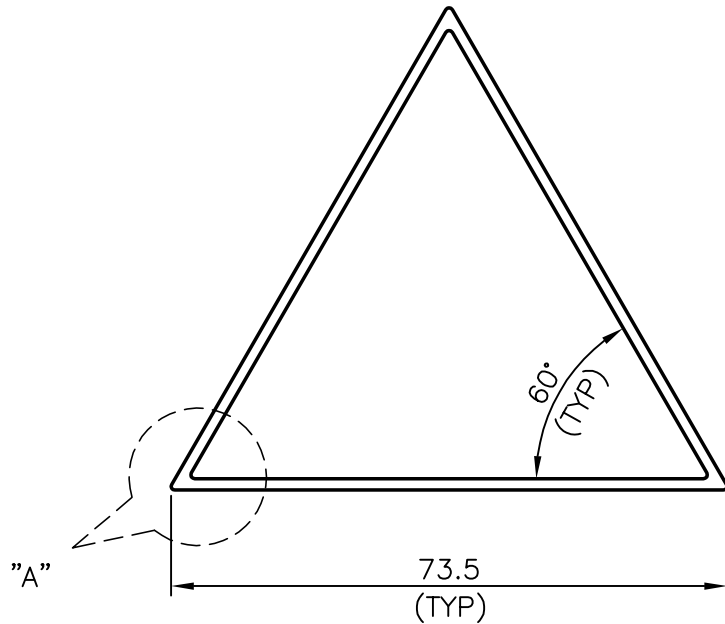

S332
2784
20353

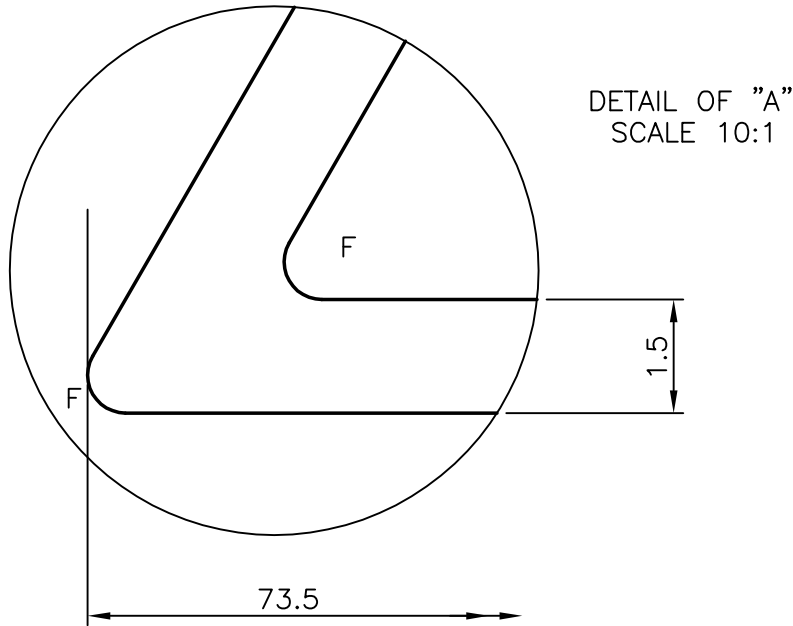

F = R0.5 mm (6 PLACES)
GENERAL WALL THICKNESS = 1.5 mm

 SYMBOL OF QUALITY AN ISO 9001 COMPANY	JINDAL ALUMINIUM LTD. BANGALORE-560073 (INDIA)	NAME		DATE
		DRAWN	PRASANNA.H.	10-02-2007
1. ALL DIMENSIONS ARE IN mm. 2. ROUND OFF ALL SHARP CORNERS WITH 0.40 mm. 3. TOLERANCES WILL BE AS PER IS:6477-1983 UNLESS OTHERWISE SPECIFIED		CHECKED		
		APPROVED		
PARTY'S NAME HI-TRICKS DISPLAY ENGINEERING, CHENNAI		SCALE		1:1
		AREA mm ²		322.353
PARTY'S DRAWING No. AS PER SKETCH		PERIMETER mm.		220.642
		WEIGHT kg/m		0.87
ALLOY & TEMPER HE9 WP		DRAWING No.		SECTION No.
		S332		S332
DESCRIPTION MISC. TUBE		2784		2784
		20353		20353