

P-3825

2805

20354

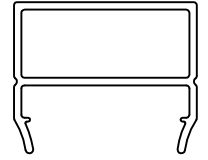

SCALE 1:1

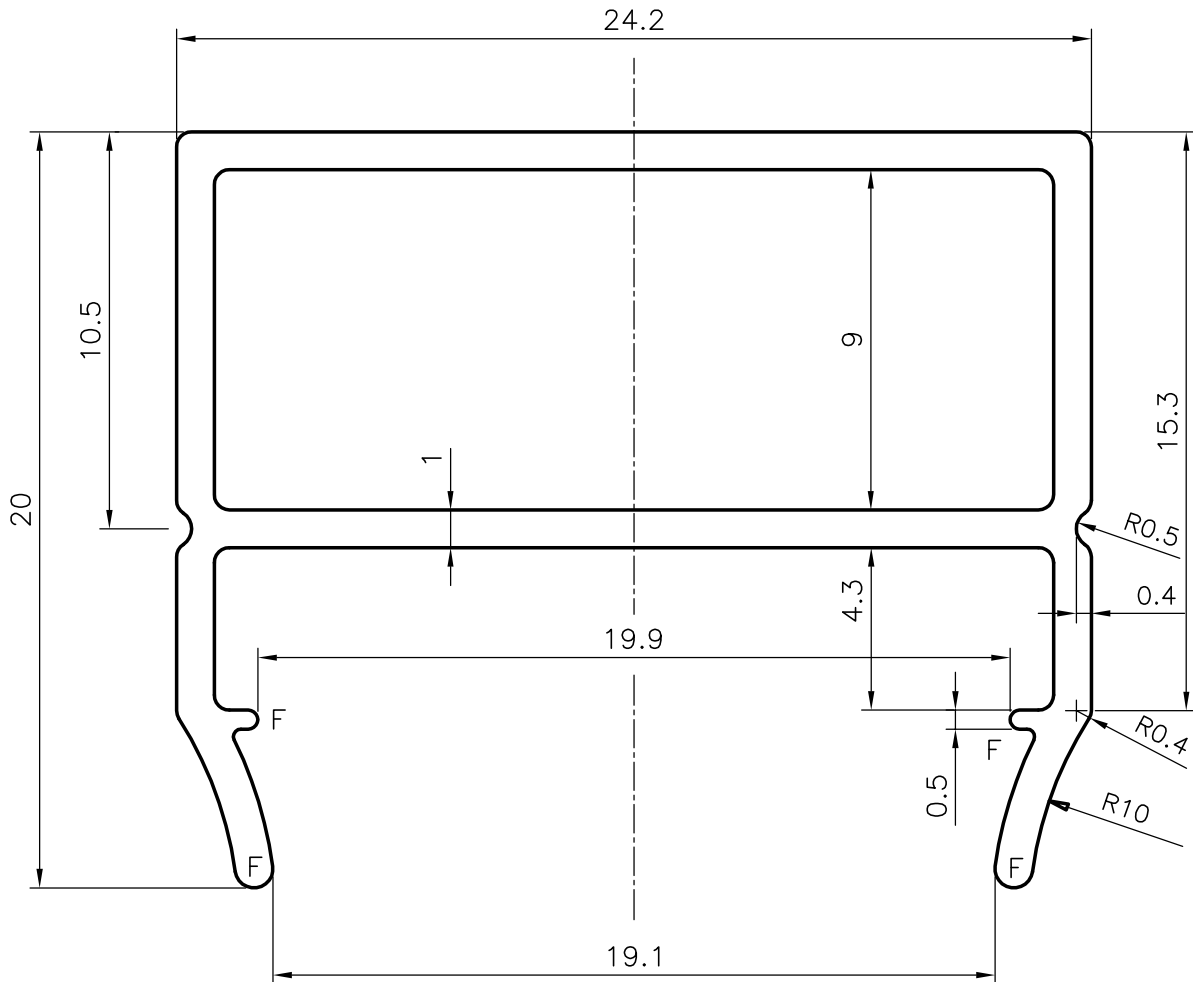

GENERAL WALL THICKNESS = 1.00mm  
 F = FULL RADII (4 PLACES)



SYMBOL OF QUALITY  
 AN ISO 9002 COMPANY

**JINDAL ALUMINIUM LTD.**  
 BANGALORE-560073 (INDIA)

	NAME	DATE
DRAWN	RAGHAVENDRA	08-04-02
CHECKED		
APPROVED		

1. ALL DIMENSIONS ARE IN mm.
2. ROUND OFF ALL SHARP CORNERS WITH 0.40 mm.
3. TOLERANCES WILL BE AS PER IS 6477-1983 UNLESS OTHERWISE SPECIFIED

SCALE	5:1 & 1:1
AREA mm <sup>2</sup>	85.05
PERIMETER	109.24mm
WEIGHT kg/m	0.230
SECTION No.	20354
DRAWING No.	20354

PARTY'S NAME	GENERAL CATEGORY ., DELHI MARKET
PARTY'S DRAWING No.	AS PER SAMPLE
ALLOY & TEMPER	HE9 WP
DESCRIPTION	-