

S582

2910

20369

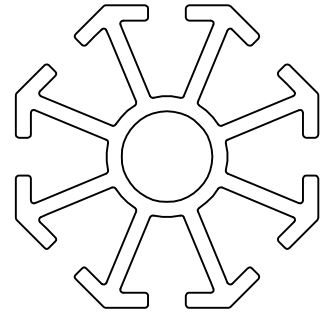

1:1

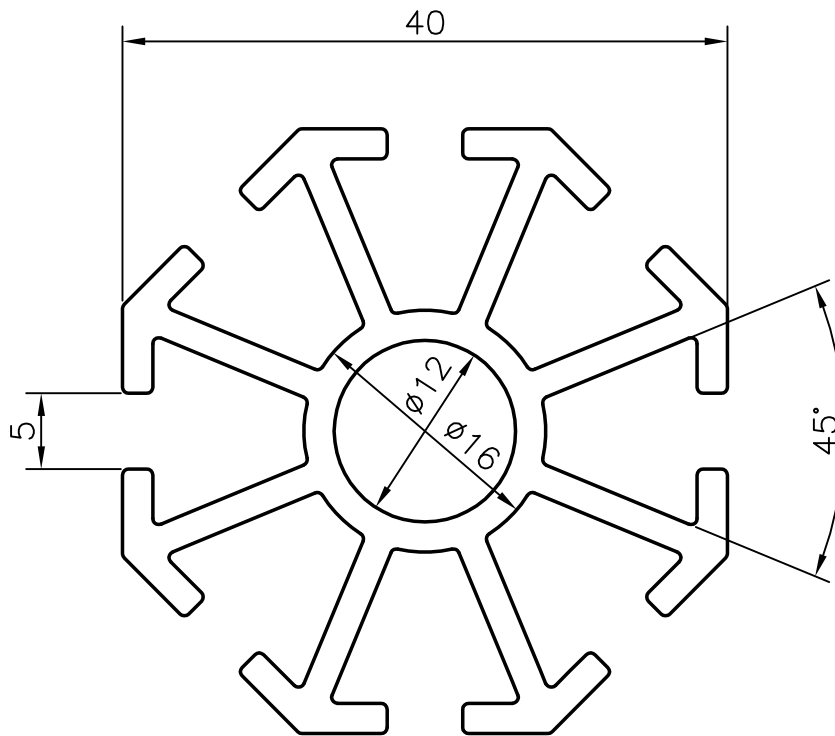

GENERAL WALL THICKNESS:- 2 mm.

 SYMBOL OF QUALITY AN ISO 9002 COMPANY	<b>JINDAL ALUMINIUM LTD.</b> BANGALORE-560073 (INDIA)		NAME	DATE
		DRAWN	RANGASWAMY	16-10-2K
1. ALL DIMENSIONS ARE IN mm. 2. ROUND OFF ALL SHARP CORNERS WITH 0.40 mm. 3. TOLERANCES WILL BE AS PER IS 6477-1983 UNLESS OTHERWISE SPECIFIED		CHECKED		
		APPROVED		
PARTY'S NAME FABRICANA INTERIOR DECORATORS, BANGALORE		SCALE		2:1
		WEIGHT kg/m		1.191
PARTY'S DRAWING No. DRAWING:A		SECTION No.		20369
ALLOY & TEMPER HE9 WP		DRAWING No.		
DESCRIPTION DISPLAY SECTION		20369		