

S219

8145

20396

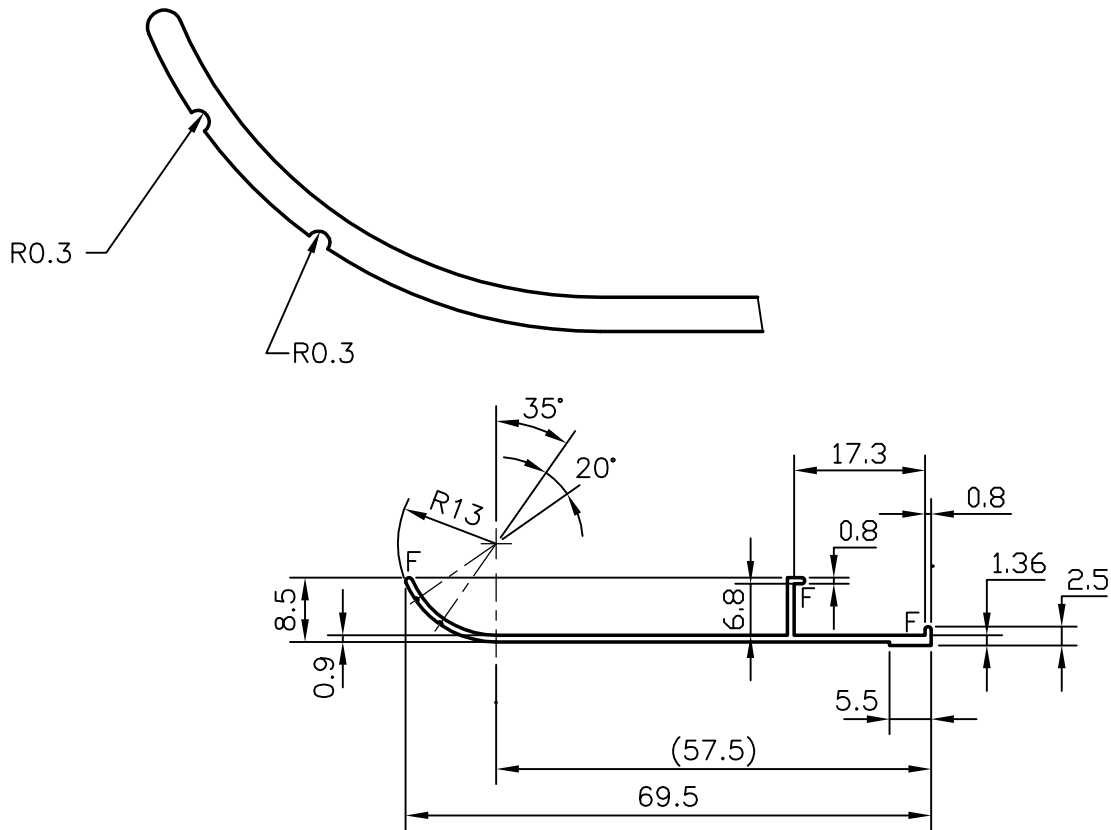

GENERAL WALL THICKNESS :- 0.90 mm.

F = FULL RADIUS (3)

MATCHING SECTION :- 20395

JINDAL ALUMINIUM LTD.**BANGALORE-560073**

NAME

DATE

DRAWN

R.D.Sharma

06-04-98

CHECKED

APPROVED

1. ALL DIMENSIONS ARE IN mm.
 2. ROUND OFF ALL SHARP CORNERS WITH 0.4 mm.
 3. TOLERANCES WILL BE AS PER IS: 3965-1981 ,UNLESS OTHERWISE SPECIFIED

PARTY'S NAME

ALKOSIGN DISPLAY SYSTEMS, MUMBAI

SCALE

1:1 & 5:1

PARTY'S DRAWING No.

NIL

WEIGHT kg/m

0.204

ALLOY & TEMPER

HE9 WP

SECTION No.

20396

LENGTH

3658 mm.

DRAWING No.

20396

DESCRIPTION

-