

X192

8182

20412



SCALE 1;1

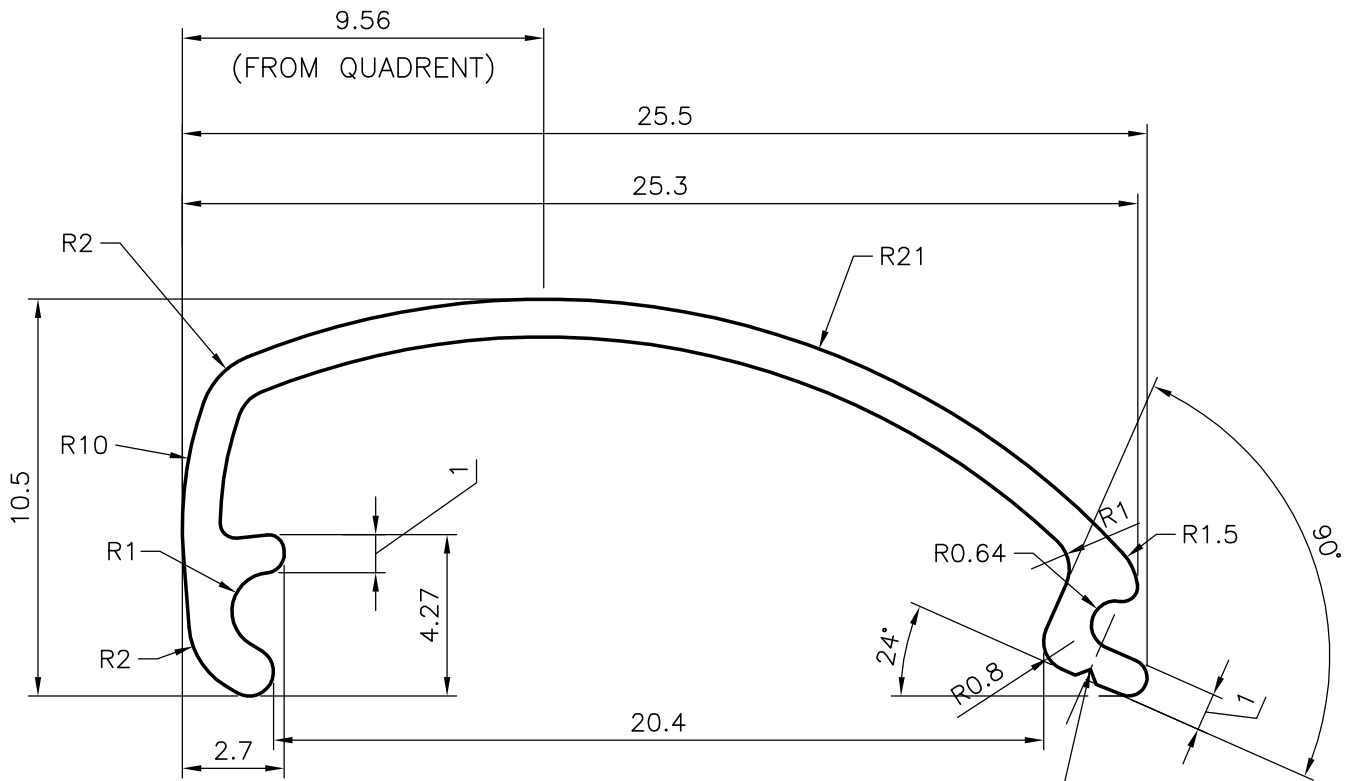

GENERAL WALL THICKNESS :-1.0 mm

PERIMETER mm. :- 81.25 mm



SYMBOL OF QUALITY
AN ISO 9002 COMPANY

JINDAL ALUMINIUM LTD.
BANGALORE-560073 (INDIA)

	NAME	DATE
DRAWN	RANGASWAMY	15-04-01
CHECKED		
APPROVED		
SCALE	5:1 & 1:1	
WEIGHT kg/m	0.113	
SECTION No.	20412	
DRAWING No.	20412	

1. ALL DIMENSIONS ARE IN mm.
2. ROUND OFF ALL SHARP CORNERS WITH 0.40 mm.
3. TOLERANCES WILL BE AS PER I.S 3965-1981 UNLESS OTHERWISE SPECIFIED

PARTY'S NAME	ADMIRE SIGN & DISPLAY PVT LTD MUMBAI
PARTY'S DRAWING No.	AS PER NEW SAMPLE
ALLOY & TEMPER	HE9 WP
DESCRIPTION	GENERAL MISC