

P-2839
X121
8264
20424

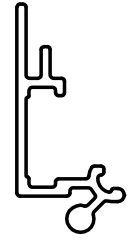

1:1 EXTRUDE MANUFACTURE SHAPE

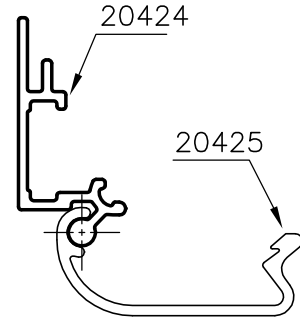

1:1 ASS'Y POSITION ONLY

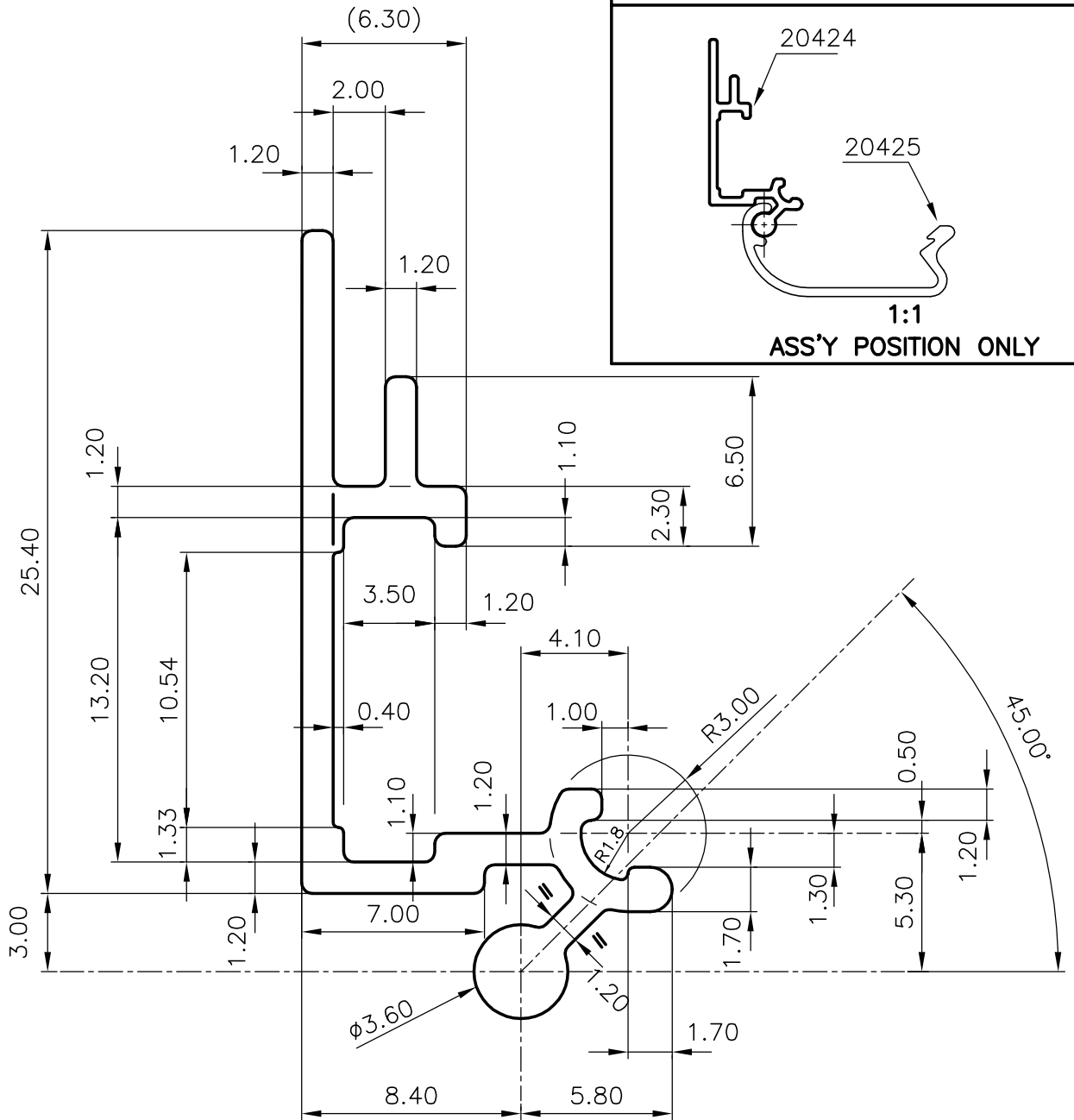

 SYMBOL OF QUALITY AN ISO 9002 COMPANY	JINDAL ALUMINIUM LTD. BANGALORE-560073 (INDIA)	NAME	DATE
		DRAWN	P,KULKARNI 4-7-2000
1. ALL DIMENSIONS ARE IN mm. 2. ROUND OFF ALL SHARP CORNERS WITH 0.40 mm. 3. TOLERANCES WILL BE AS PER I.S. 3965-1981 UNLESS OTHERWISE SPECIFIED		CHECKED	
		APPROVED	
		SCALE	4:1
PARTY'S NAME	ADMIRE SIGN & DISPLAY PVT LTD., MUMBAI.	WEIGHT kg/m	0.212
PARTY'S DRAWING No.	AS PER SAMPLE	SECTION No.	20424
ALLOY & TEMPER	HE9 WP	DRAWING No. 20424	
DESCRIPTION	MISC SECTION		