

P-2840
X122
8265
20425

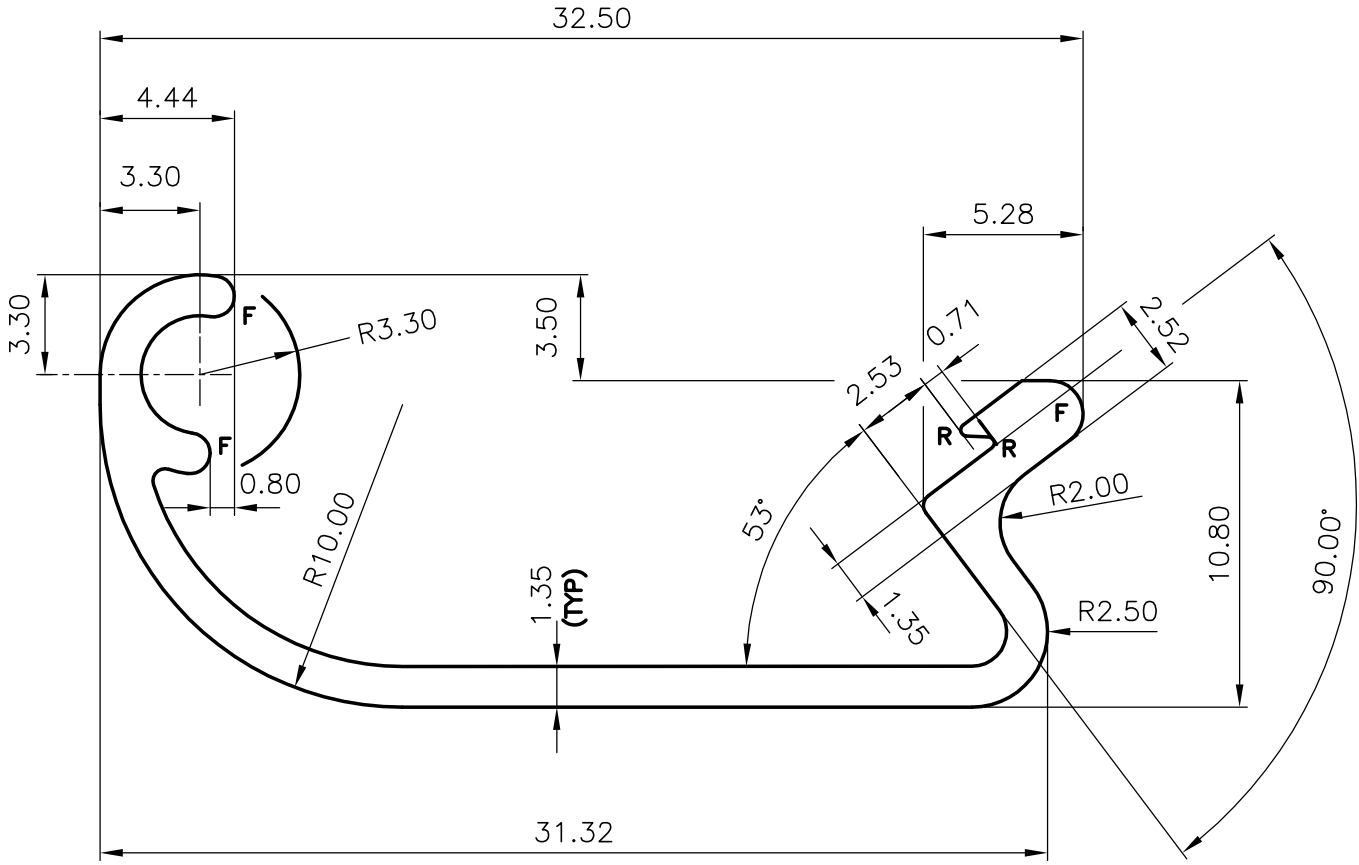
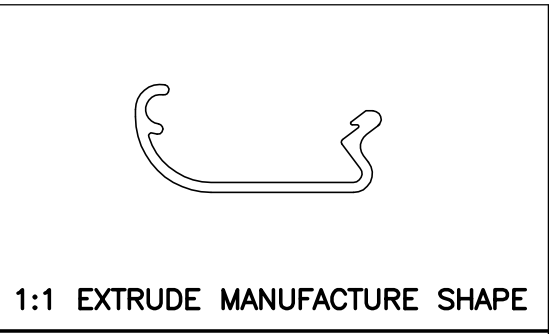
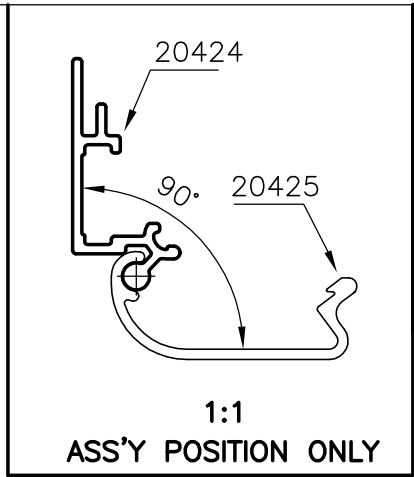

**GENERAL WALL THICKNESS 1.35 mm**  
**R = RADII 0.20 (2-PLACES)**  
**F = RADII FULL (3-PLACES)**

<p>SYMBOL OF QUALITY AN ISO 9002 COMPANY</p>	<p><b>JINDAL ALUMINIUM LTD.</b> BANGALORE-560073 (INDIA)</p>		NAME	DATE
		DRAWN	P,KULKARNI	4-7-2000
<p>1. ALL DIMENSIONS ARE IN mm.  2. ROUND OFF ALL SHARP CORNERS WITH 0.40 mm.  3. TOLERANCES WILL BE AS PER I.S. 3965-1981 UNLESS OTHERWISE SPECIFIED</p>		CHECKED		
		APPROVED		
PARTY'S NAME	ADMIRE SIGN & DISPLAY PVT LTD, MUMBAI.	SCALE	4:1	
PARTY'S DRAWING No.	AS PER SAMPLE	WEIGHT kg/m	0.213	
ALLOY & TEMPER	HE9 WP	SECTION No.	20425	
DESCRIPTION	MISC SECTION	DRAWING No.	20425	