

P-4436-1

S1059

85100

20441

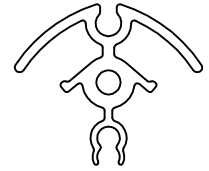

1:1

F= FULL RADIOUS (2)

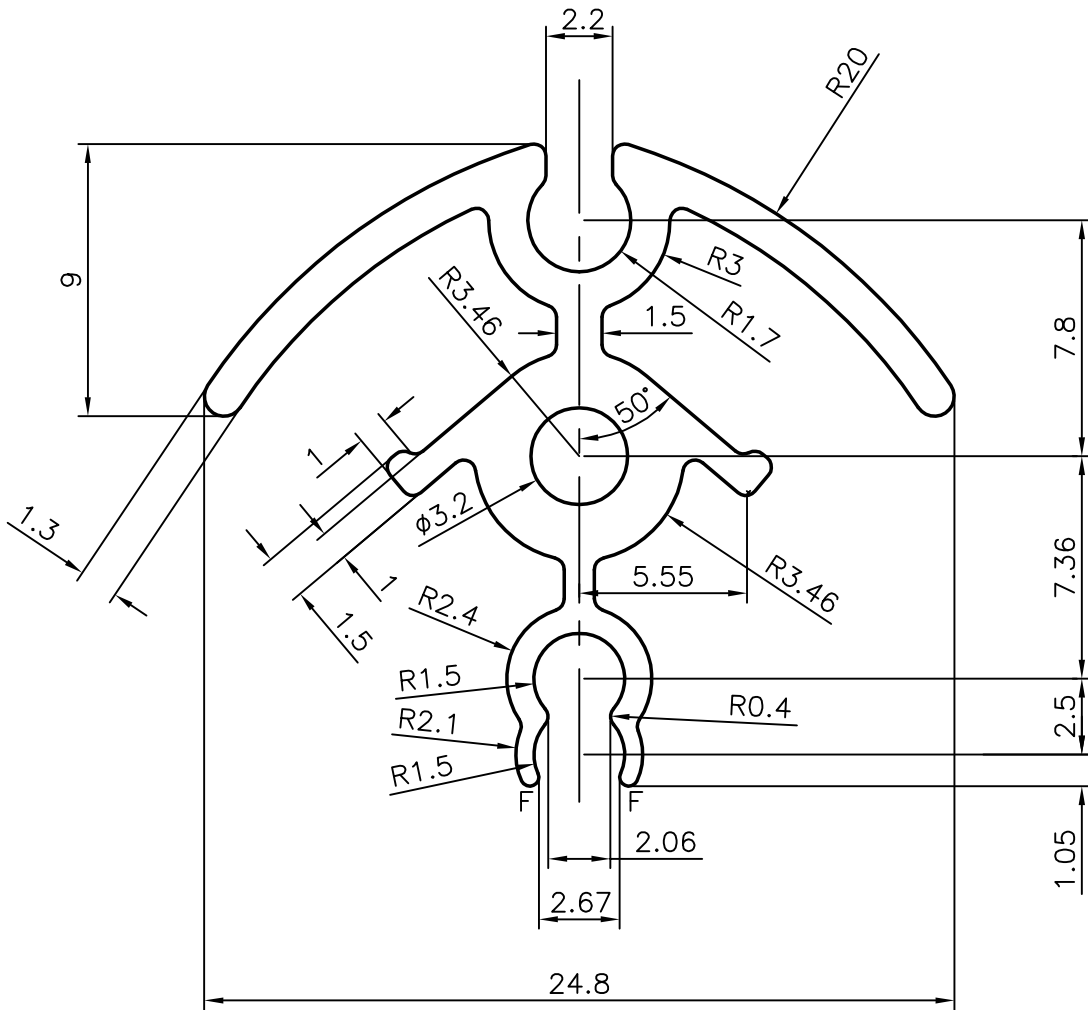

SYMBOL OF QUALITY
AN ISO 9001 COMPANY

JINDAL ALUMINIUM LTD.
BANGALORE-560073 (INDIA)

	NAME	DATE
DRAWN	MALINGAPPA	24-09-2003
CHECKED		
APPROVED		

1. ALL DIMENSIONS ARE IN mm.
2. ROUND OFF ALL SHARP CORNERS WITH 0.40 mm.
3. TOLERANCES WILL BE AS PER IS: 6477-1983 UNLESS OTHERWISE SPECIFIED

SCALE	4:1
AREA mm ²	101.1
PERIMETER mm.	135.9
WEIGHT kg/m	0.272

PARTY'S NAME	ADMIRE SIGN AND DISPLAY PVT. LTD., MUMBAI	DRAWING No.	P-4436-1	SECTION No.	-
PARTY'S DRAWING No.	AS PER SAMPLE		S1059		S1059
ALLOY & TEMPER	HE9 WP		85100		85100
DESCRIPTION	DISPLAY SECTION		20441		20441