

P-4958

20447

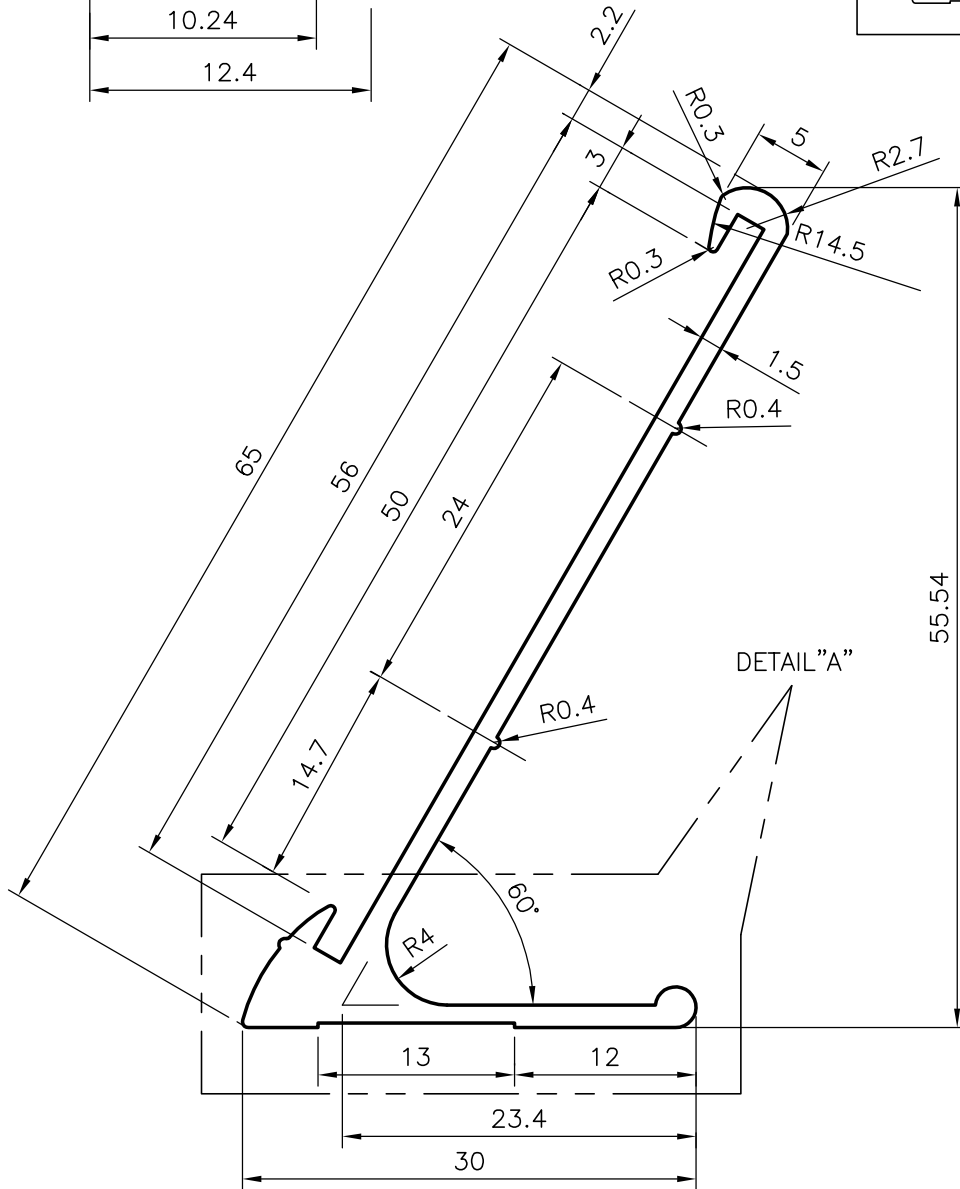
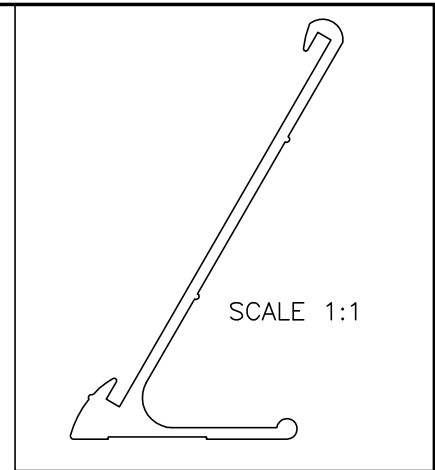
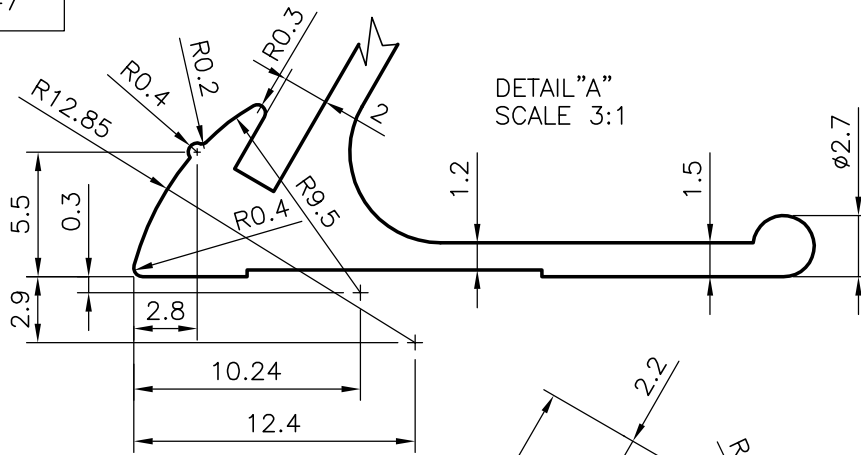

SYMBOL OF QUALITY
AN ISO 9002 COMPANY

JINDAL ALUMINIUM LTD.
BANGALORE-560073 (INDIA)

	NAME	DATE
DRAWN	RAGHAVENDRA	06-07-2004
CHECKED		
APPROVED		

1. ALL DIMENSIONS ARE IN mm.
2. ROUND OFF ALL SHARP CORNERS WITH 0.40 mm.
3. TOLERANCES WILL BE AS PER BS:1474-1987 UNLESS OTHERWISE SPECIFIED

SCALE	2:1
AREA mm ²	175.36
PERIMETER mm.	197.736
WEIGHT kg/m	0.473

PARTY'S NAME JOSEPH INDUSTRIES, DUBAI

PARTY'S DRAWING No. AS PER DRAWING

ALLOY & TEMPER 6063 T6

DESCRIPTION DISPLAY SECTION

DRAWING No.	SECTION No.
P-4958	-
20447	20447