

P-3814

X244

20448

EXPOSED
SURFACE

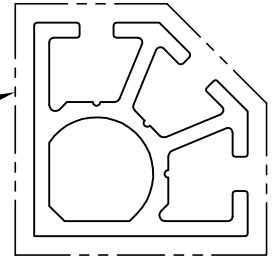

SCALE 1:1

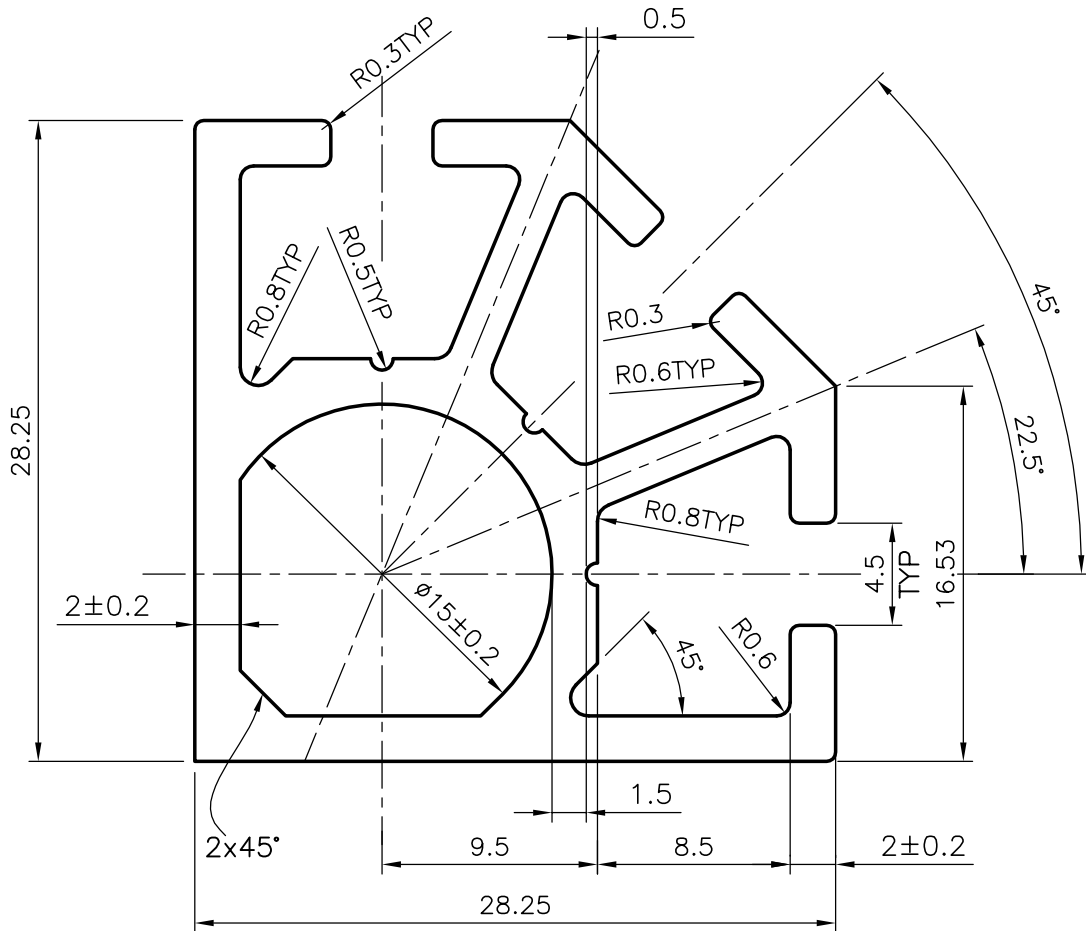

1. GENERAL WALL THICKNESS = 2 ± 0.2



SYMBOL OF QUALITY
AN ISO 9002 COMPANY

JINDAL ALUMINIUM LTD.
BANGALORE-560073 (INDIA)

	NAME	DATE
DRAWN	RAGHAVENDRA	21-03-02
CHECKED		
APPROVED		

- ALL DIMENSIONS ARE IN mm.
- ROUND OFF ALL SHARP CORNERS WITH 0.40 mm.
- TOLERANCES WILL BE AS PER IS 6477-1983 UNLESS OTHERWISE SPECIFIED

SCALE	3:1 & 1:1
AREA mm ²	272.38
PERIMETER	205.25mm
WEIGHT kg/m	0.735
SECTION No.	20448
DRAWING No.	20448

PARTY'S NAME	MEROFORM INDIA PVT LTD , NOIDA
PARTY'S DRAWING No.	AS PER DRAWING (MBN 8003)
ALLOY & TEMPER	HE9 WP (Al Mg Si 0.5 F-22)
DESCRIPTION	DISPLAY SECTION