

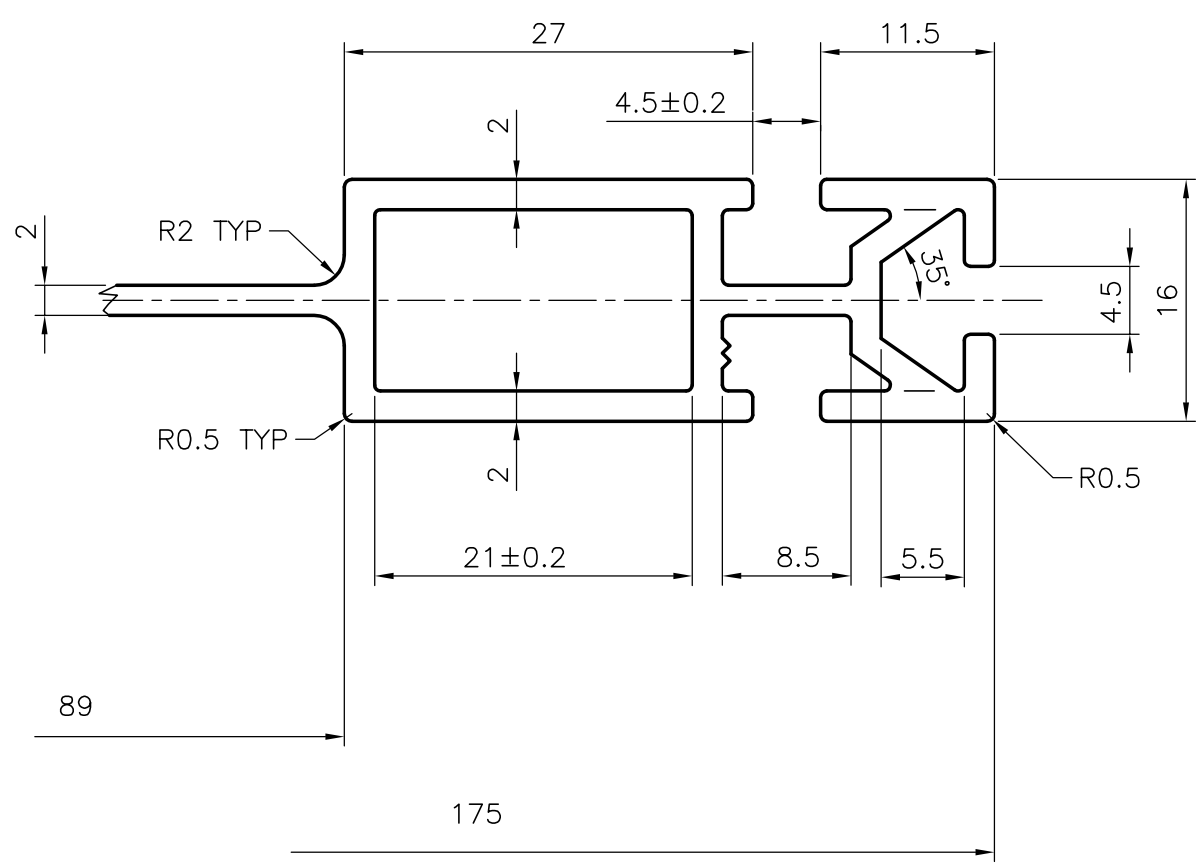

P-3195  
 X162-ISSUE-2  
 20470

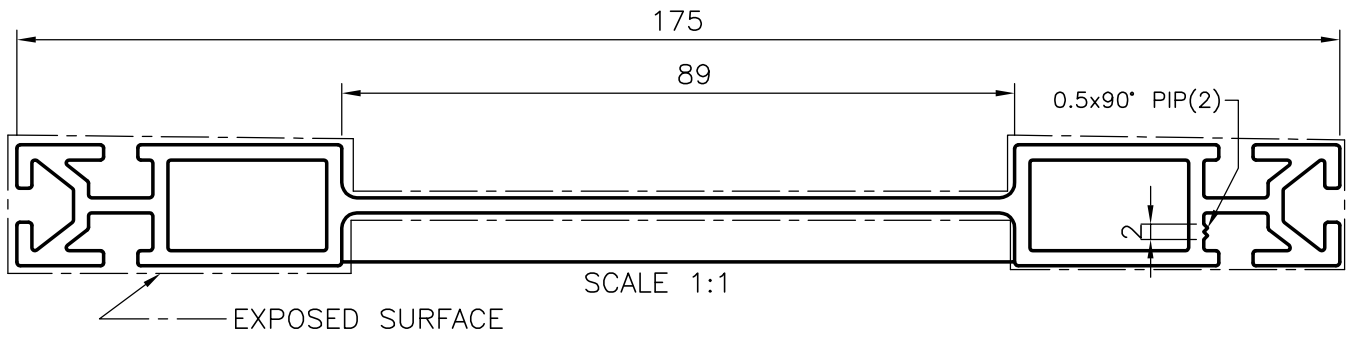

1. GENERAL WALL THICKNESS=2mm

 SYMBOL OF QUALITY AN ISO 9002 COMPANY	<b>JINDAL ALUMINIUM LTD.</b> BANGALORE-560073 (INDIA)	NAME	DATE
		DRAWN	RAGHAVENDRA 17-07-01
		CHECKED	
1. ALL DIMENSIONS ARE IN mm. 2. ROUND OFF ALL SHARP CORNERS WITH 0.40 mm. 3. TOLERANCES WILL BE AS PER IS 6477-1983 UNLESS OTHERWISE SPECIFIED		APPROVED	
		SCALE	2:1 & 1:1
		WEIGHT kg/m	1.931
PARTY'S NAME	MEROFORM INDIA PVT LTD DELHI	PERIMETER	642.13
PARTY'S DRAWING No.	AS PER DRAWING (MBN 8032)	SECTION No.	20470
ALLOY & TEMPER	HE9 WP	DRAWING No.	20470
DESCRIPTION	MISC. HOLLOW SECTION		