

P-5445-1

S1480

20474

STRAIGHTNESS = 1.7mm/M
 TWIST = $\pm 2^\circ$
 FLATNESS = ± 0.20
 F = FULL RADIUS (8 PLACES)

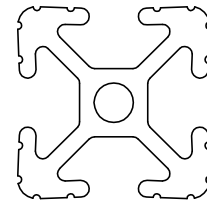

SCALE 1:1

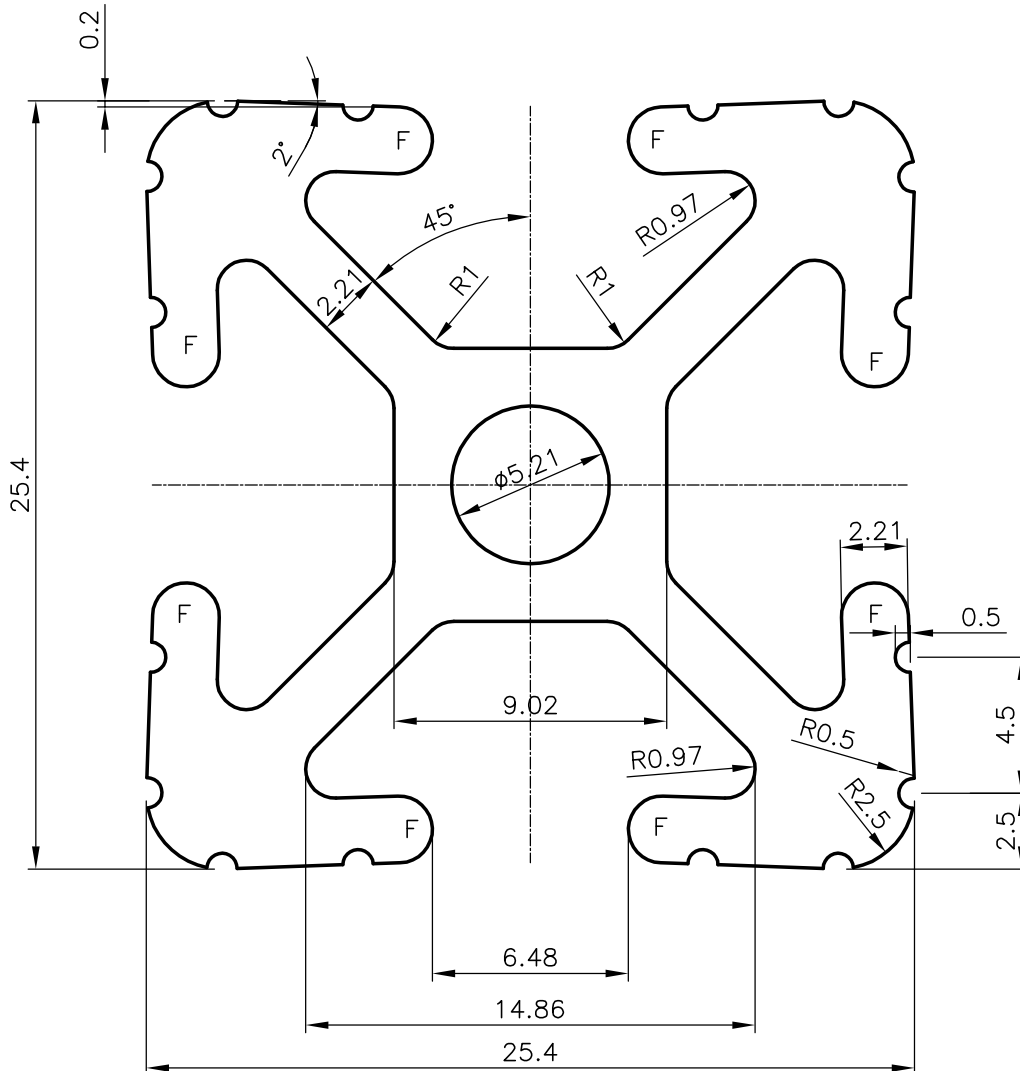

SYMBOL OF QUALITY
 AN ISO 9001 COMPANY

JINDAL ALUMINIUM LTD.
 BANGALORE-560073 (INDIA)

	NAME	DATE
DRAWN	RAGHAVENDRA	02-05-2005
CHECKED		
APPROVED		

1. ALL DIMENSIONS ARE IN mm.
2. ROUND OFF ALL SHARP CORNERS WITH 0.40 mm.
3. TOLERANCES WILL BE AS PER IS:6477-1983 UNLESS OTHERWISE SPECIFIED

SCALE	4:1
AREA mm ²	276.762
PERIMETER mm.	204.95
WEIGHT kg/m	0.747

PARTY'S NAME	ION AMERICA CHENNAI (P) LIMITED., CHENNAI
PARTY'S DRAWING No.	AS PER DRAWING
ALLOY & TEMPER	63400 WP
DESCRIPTION	DISPLAY SECTION

DRAWING No.	SECTION No.
P-5445-1	-
S1480	S1480
20474	20474