

4788

12343

20528

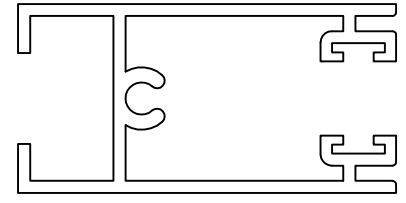

SCALE 1:1

DETAIL OF "A"
SCALE 3:1

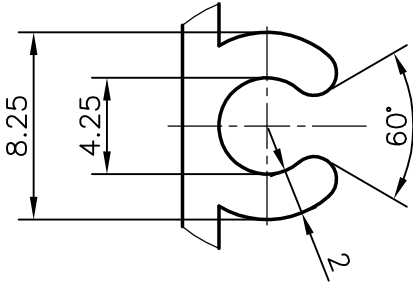

DETAIL OF "B"
SCALE 3:1

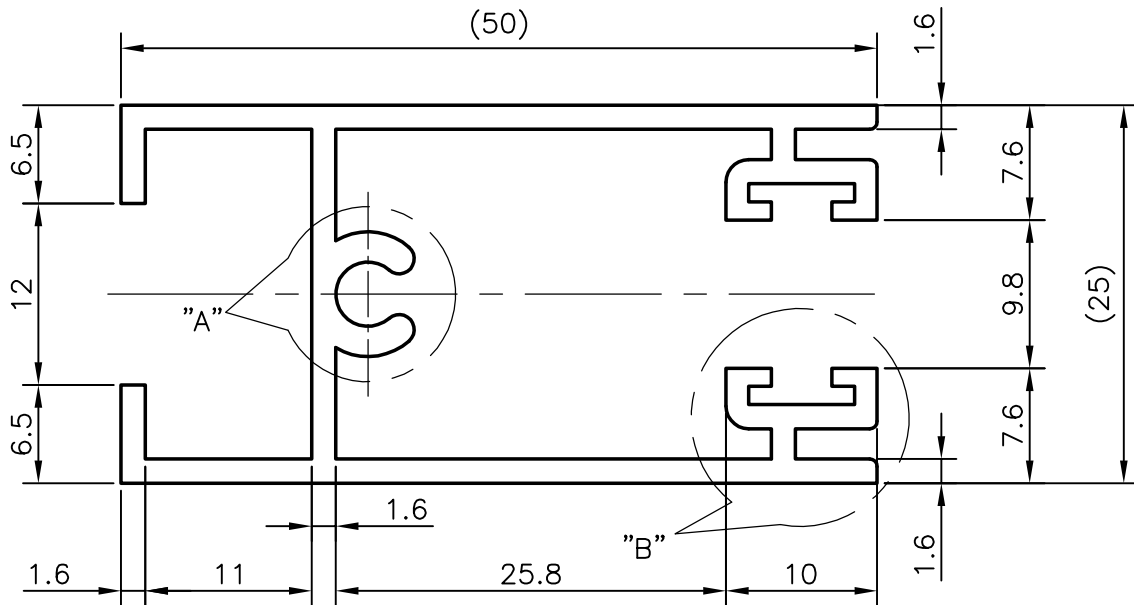
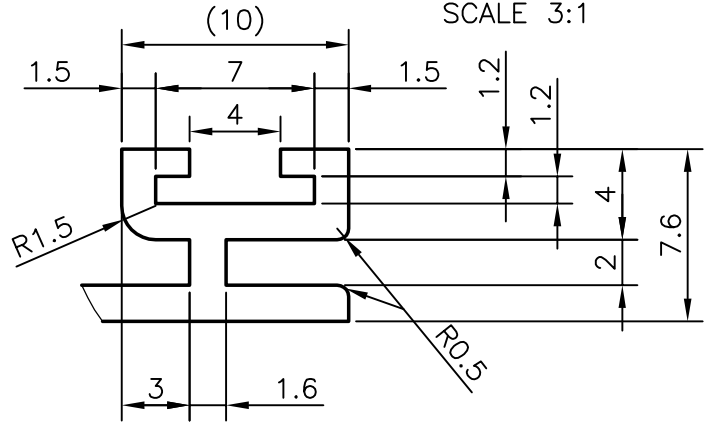

GENERAL WALL THICKNESS = 1.6 mm



SYMBOL OF QUALITY
AN ISO 9002 COMPANY

JINDAL ALUMINIUM LTD.
BANGALORE-560073 (INDIA)

NAME DATE

DRAWN R.D.Sharma 19-05-2000

CHECKED

APPROVED

SCALE 2:1

PARTY'S NAME

-

WEIGHT kg/m 0.786

PARTY'S DRAWING No.

-

SECTION No. 20528

ALLOY & TEMPER

6063 T6

DRAWING No.

DESCRIPTION

WINDOW SECTION

20528

1. ALL DIMENSIONS ARE IN mm.
2. ROUND OFF ALL SHARP CORNERS WITH 0.40 mm.
3. TOLERANCES WILL BE AS PER IS 3965-1981 UNLESS OTHERWISE SPECIFIED