

8117
12015
20546

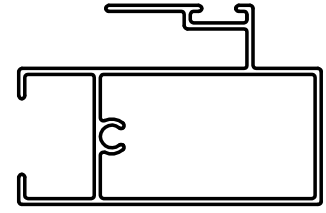

1:1

F = RADII FULL (5)

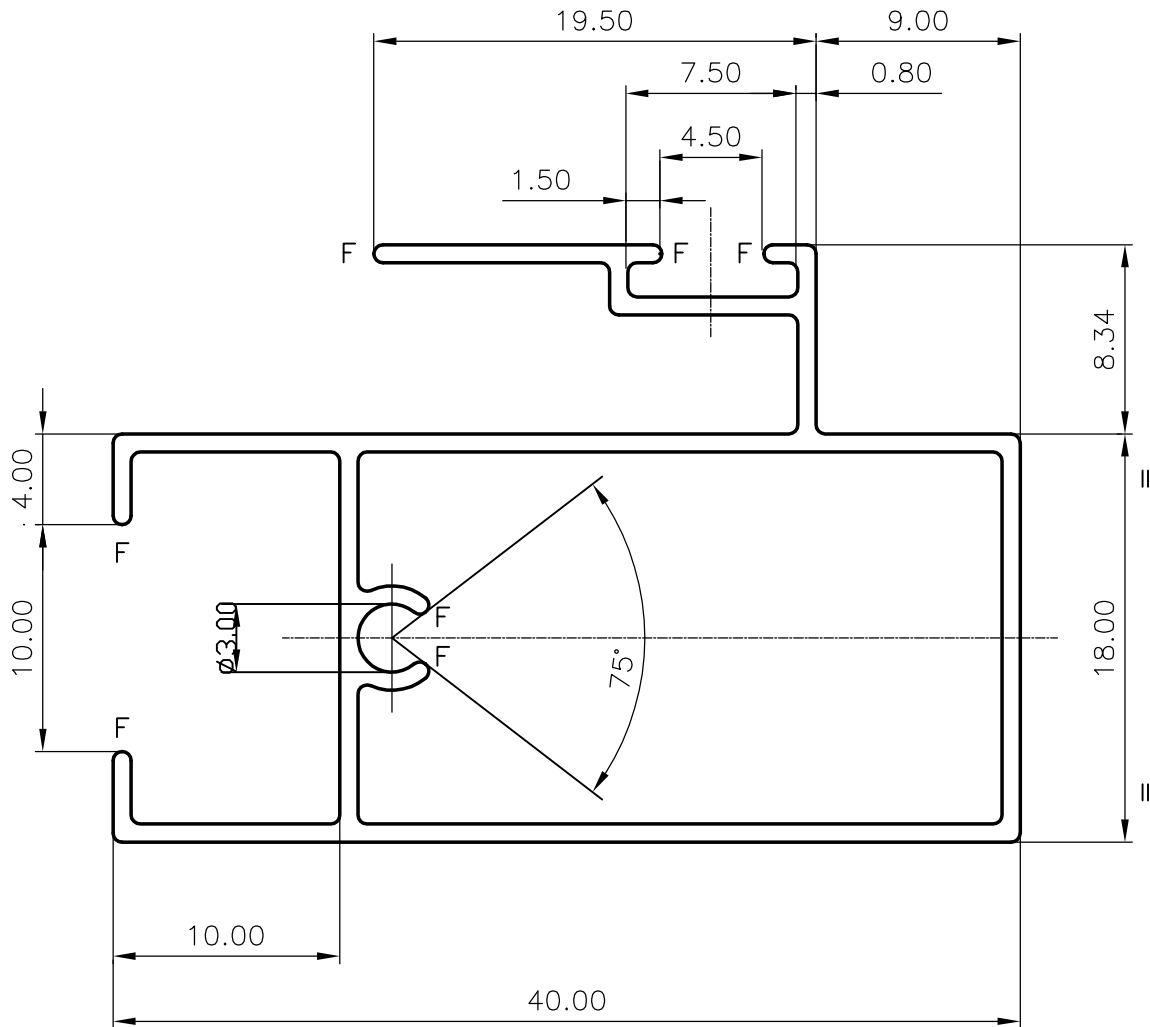

1. GENERAL WALL THICKNESS :- 0.80 mm.
2. 3658 mm. LONG PIECES IN 100 kgs. :- 78 (AVERAGE)

JINDAL ALUMINIUM LTD.
BANGALORE-560073

1. ALL DIMENSIONS ARE IN mm.
2. ROUND OFF ALL SHARP CORNERS WITH 0.4 mm.
3. TOLERANCES WILL BE AS PER IS: 6477-1983 UNLESS OTHERWISE SPECIFIED

	NAME	DATE
DRAWN	P,KULKARNI	9-5-99
CHECKED		
APPROVED		
SCALE	3:1	
WEIGHT kg/m	0.346	
SECTION No.	20546	
DRAWING No.	20546	

PARTY'S NAME	GENERAL CATEGORY (MUMBAI MARKET)
PARTY'S DRAWING No.	-
ALLOY & TEMPER	HE9 WP
LENGTH	3658 mm.
DESCRIPTION	WINDOW SECTION