

8713

11833

20642

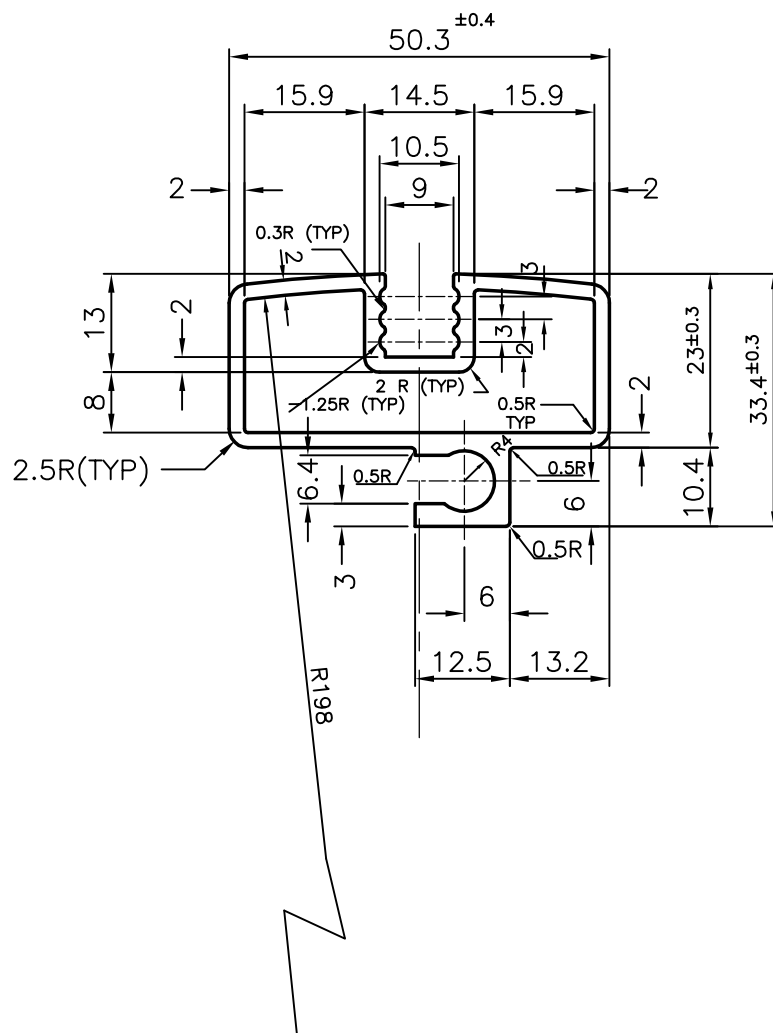

SYMBOL OF QUALITY
AN ISO 9002 COMPANY

JINDAL ALUMINIUM LTD.
BANGALORE-560073 (INDIA)

	NAME	DATE
DRAWN	R.D.SHARMA	16-4-83
CHECKED		
APPROVED		
SCALE	1:1	
WEIGHT kg/m	0.997	
SECTION No.	20642	
DRAWING No.	20642	

1. TOLERANCES WILL BE AS PER I.S.6477-1983, UNLESS OTHERWISE SPECIFIED.
2. ALL DIMENSIONS ARE IN MM
3. ROUND OF SHARP CORNERS WITH 0.4 MM R

PARTY'S NAME

-

PARTY'S DRAWING No.

-

FINISH

AS EXTRUDED

ALLOY & TEMPER

HE9WP

LENGTH:

3658 mm.

DESCRIPTION

WINDOW SECTION