

8727

11818

20653

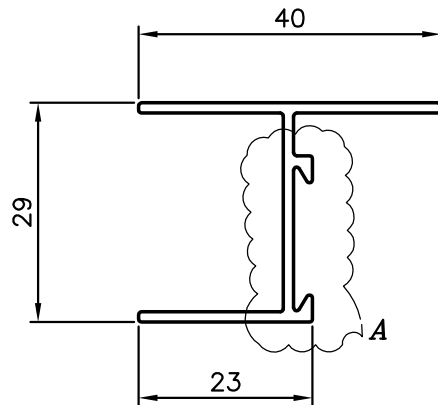

GENERAL WALLTHICKNESS :- 1.36 mm.

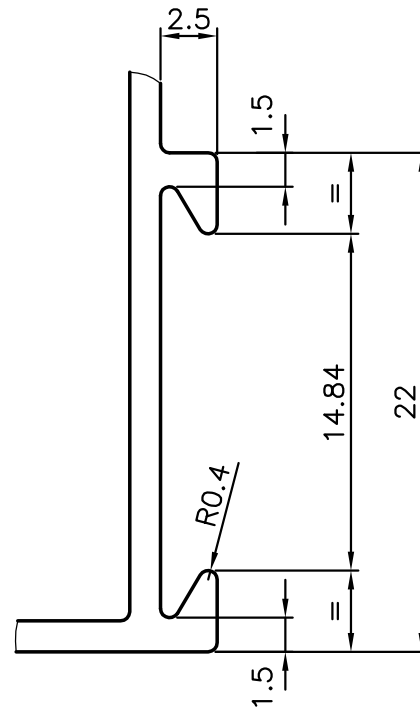

DETAIL OF "A"
SCALE :- 3:1

PLEASE SPECIFY THE EXPOSED SURFACE IN THE DRAWING WHEREVER BETTER FINISH REQUIRED.

 SYMBOL OF QUALITY AN ISO 9001 COMPANY	JINDAL ALUMINIUM LTD. BANGALORE-560073 (INDIA)	NAME	DATE
		DRAWN	PARVESH 04-10-2012
		CHECKED	
		APPROVED	
1. ALL DIMENSIONS ARE IN mm. 2. ROUND OFF ALL SHARP CORNERS WITH 0.40 mm. 3. TOLERANCES WILL BE AS PER IS:3965-1981, UNLESS OTHERWISE SPECIFIED		SCALE	1:1
		AREA mm ²	130.583
		PERIMETER mm.	189.886
PARTY'S NAME	MADRAS ALUMINIUM TRADING CO., CHENNAI	WEIGHT kg/m	0.353
PARTY'S DRAWING No.	-	DRAWING No.	SECTION No.
ALLOY & TEMPER	HE9 WP	8727	-
DESCRIPTION	WINDOW SECTION	11818	11818
		20653	20653