

8733

11821

20658

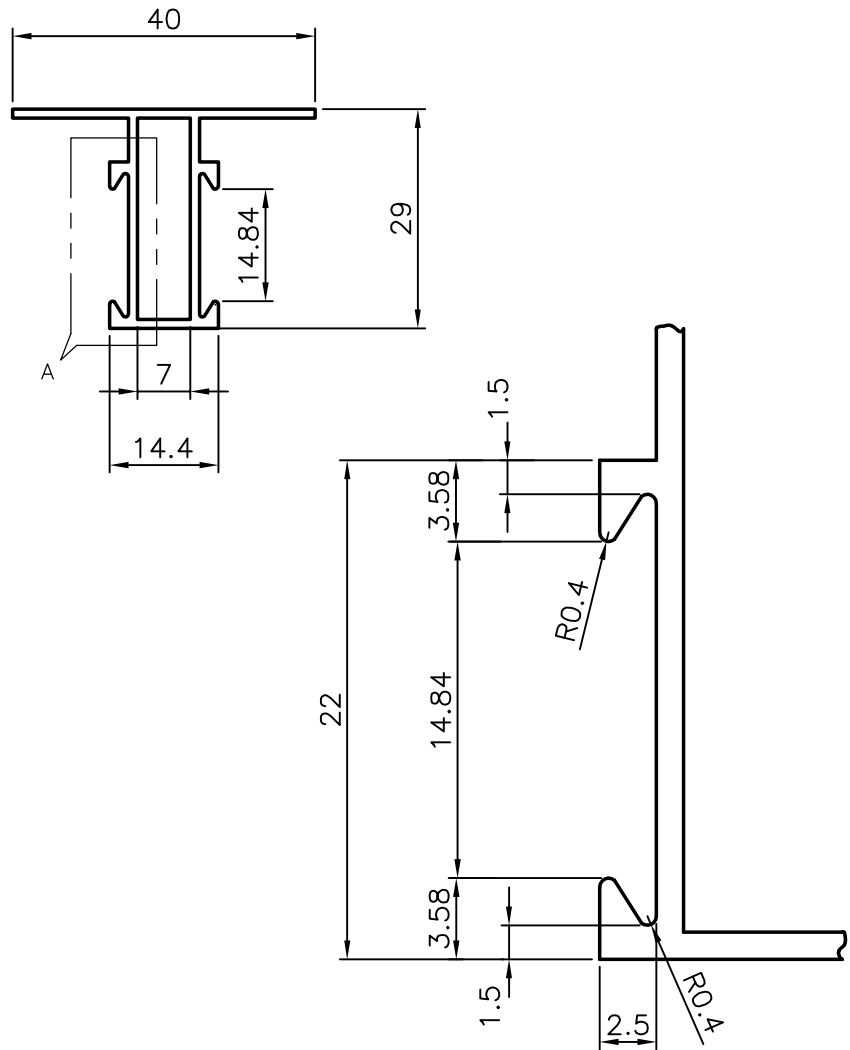

DETAIL AT 'A'

NOTE:-

1. GENERAL WALL THICKNESS= 1.2mm.

 SYMBOL OF QUALITY AN ISO 9002 COMPANY	JINDAL ALUMINIUM LTD. BANGALORE-560073 (INDIA)			NAME	DATE
				DRAWN	S.KUMAR
1. ALL DIMENSIONS ARE IN mm. 2. ROUND OFF SHARP CORNERS WITH 0.4 mm R. 3. TOLERANCE ARE AS PER IS: 6477-1983				CHECKED	
				APPROVED	
				SCALE	1:1 & 3:1
PARTY'S NAME	MADRAS ALUMINIUM TRADING Co. MADRAS.			WEIGHT kg/m	0.367
PARTY'S DRAWING No.	-	FINISH	AS EXTRUDED.	SECTION No.	20658 20658
ALLOY & TEMPER	HE 9 WP	LENGTH:	3658mm	DRAWING No.	20658 20658
DESCRIPTION	MULLION SECTION				