

8735

12482

20660

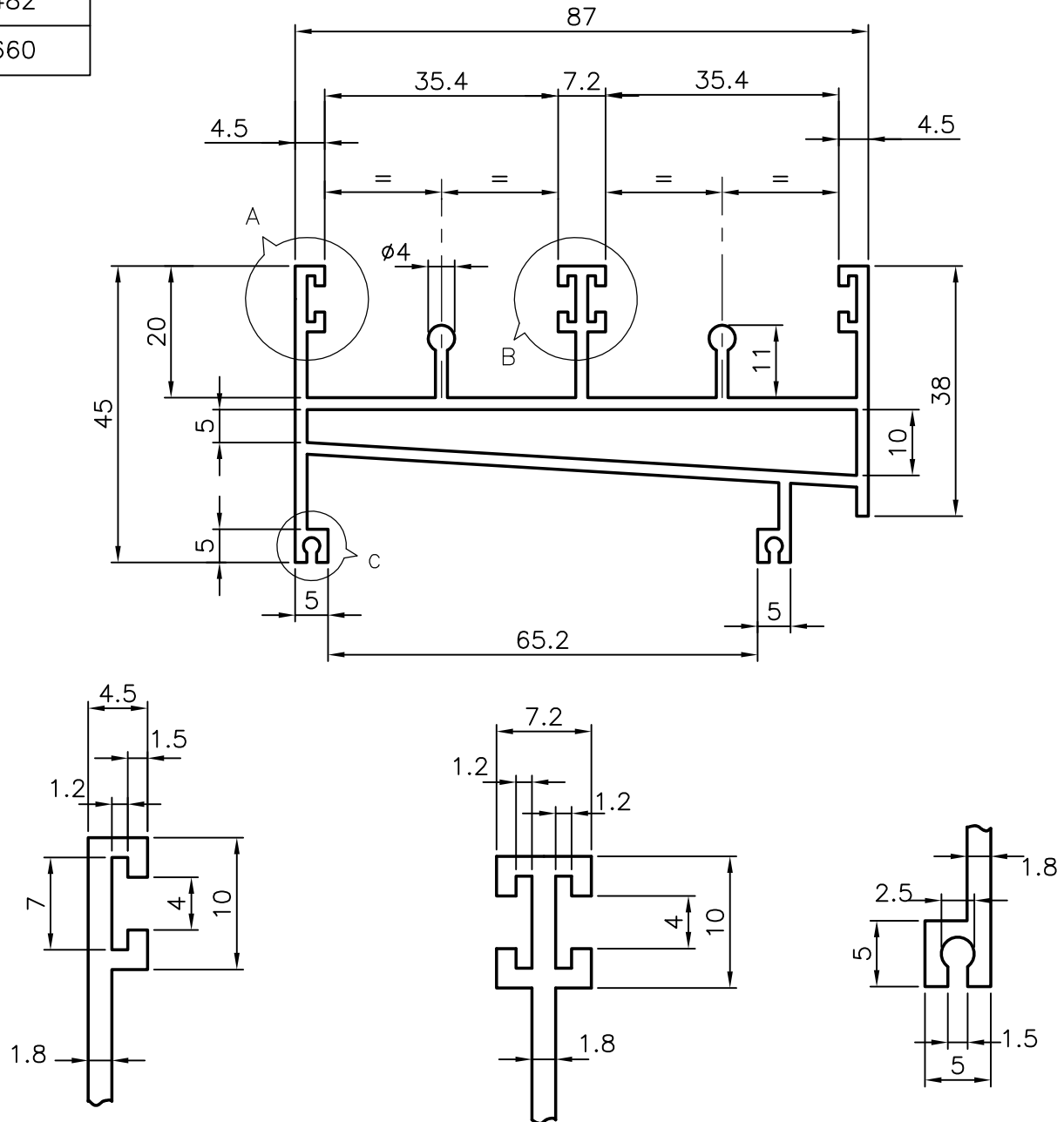

DETAIL AT 'A'

DETAIL AT 'B'

DETAIL AT 'C'

GENERAL WALL THICKNESS: 1.8mm.



SYMBOL OF QUALITY
AN ISO 9002 COMPANY

JINDAL ALUMINIUM LTD.
BANGALORE-560073 (INDIA)

	NAME	DATE
DRAWN	S.KUMAR	10-9-84
CHECKED		
APPROVED		
SCALE	1:1 & 2:1	
WEIGHT kg/m	1.709	
SECTION No.	20660	
DRAWING No.	20660	

1. ALL DIMENSIONS ARE IN mm.
2. ROUND OFF SHARP CORNERS WITH 0.4 mm R.
3. TOLERANCE ARE AS PER I.S.3965-1981.

PARTY'S NAME	ECIC (BANGALORE)		
PARTY'S DRAWING No.	RD/8/104	FINISH	AS EXTRUDED
ALLOY & TEMPER	HE9 WP	LENGTH:	3658 mm
DESCRIPTION	WINDOW SECTION		