

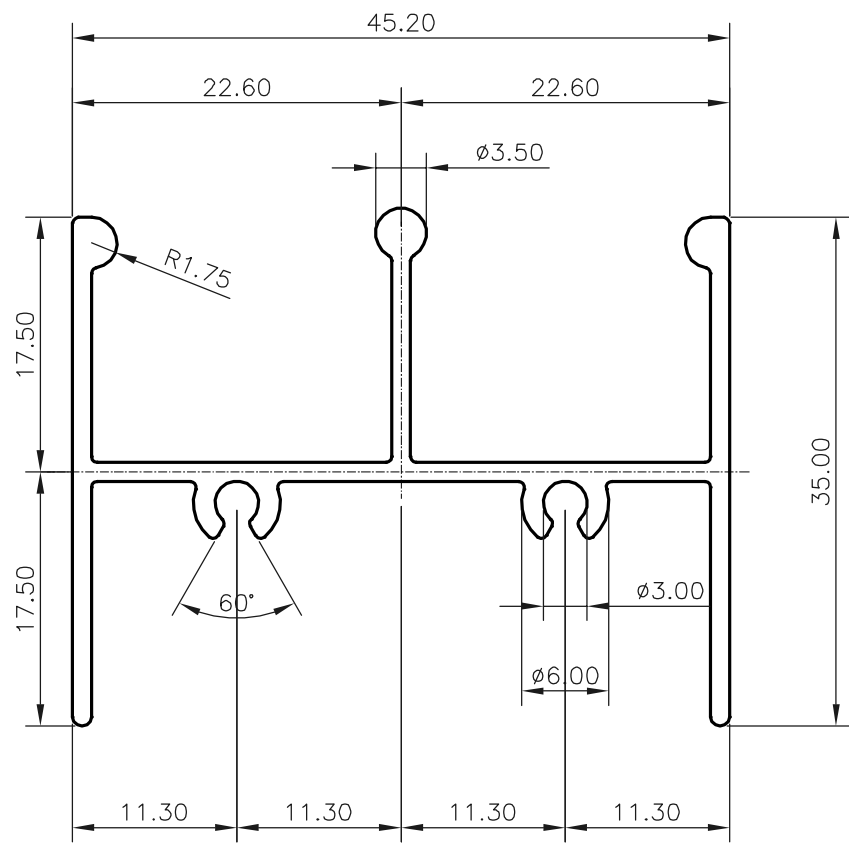

8740
11925
20664

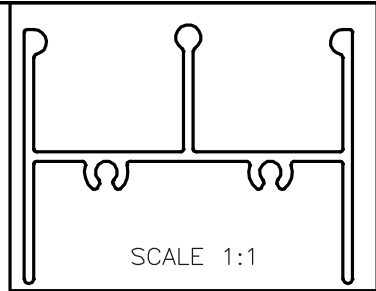

NOTE:-
 1. ALL DIMENSIONS ARE IN mm
 2. GENERAL WALL THICKNESS-1.30

 SYMBOL OF QUALITY AN ISO 9001 COMPANY	JINDAL ALUMINIUM LTD. BANGALORE-560073 (INDIA)	NAME	DATE
		DRAWN	PRASANNA.H. 13-12-2006
		CHECKED	
		APPROVED	
1. ALL DIMENSIONS ARE IN mm. 2. ROUND OFF ALL SHARP CORNERS WITH 0.40 mm. 3. TOLERANCES WILL BE AS PER IS:3965-1981 UNLESS OTHERWISE SPECIFIED		SCALE	2:1
		AREA mm ²	208.067
		PERIMETER mm.	292.593
PARTY'S NAME	ALUMET ENTERPRISES MADRAS	WEIGHT kg/m	0.562
PARTY'S DRAWING No.	-	DRAWING No.	SECTION No.
ALLOY & TEMPER	HE9 WP	8740	-
DESCRIPTION	WINDOW SECTION	11925	11925
		20664	20664