

8753

12273

20676

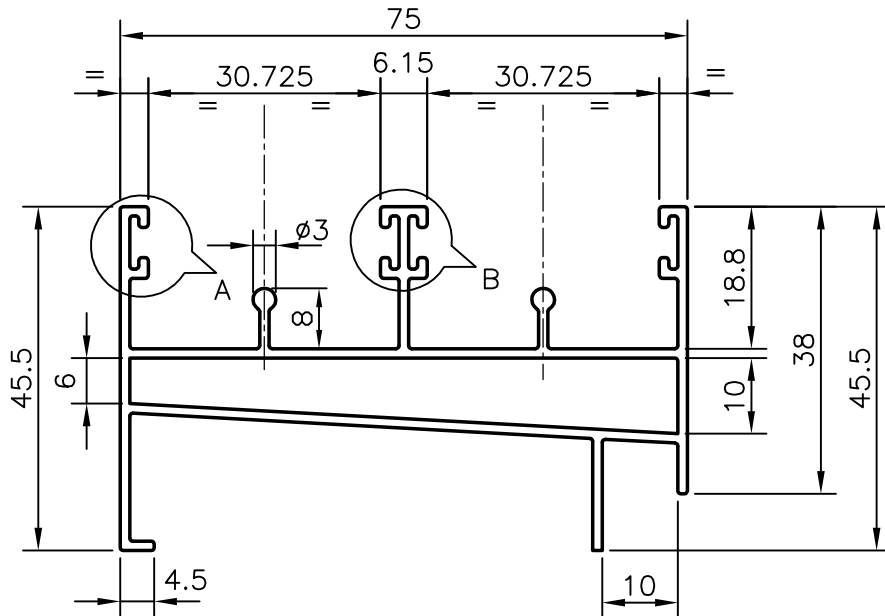

WALL THICKNESS :1.25

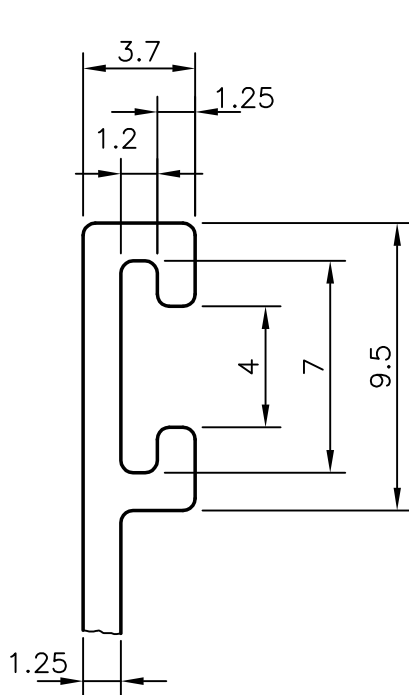

DETAIL - 'A'

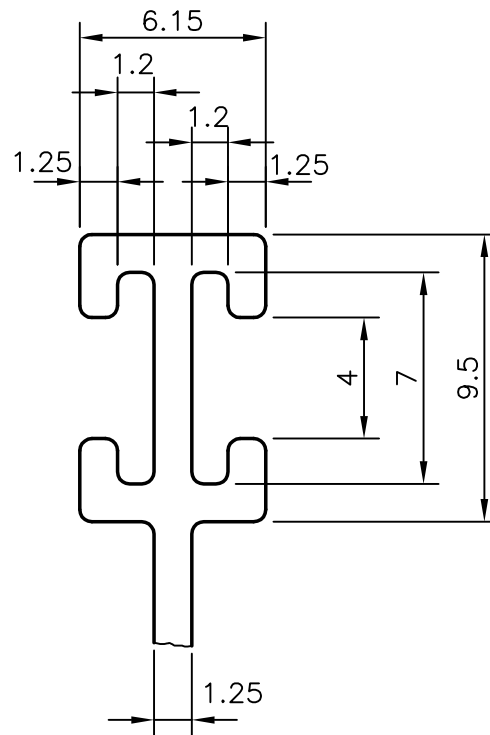

DETAIL - 'B'



SYMBOL OF QUALITY
AN ISO 9001 COMPANY

JINDAL ALUMINIUM LTD.
BANGALORE-560073 (INDIA)

	NAME	DATE
DRAWN	J.P.KAUSHIK	28-07-2006
CHECKED		
APPROVED		

1. ALL DIMENSIONS ARE IN mm.
2. ROUND OFF ALL SHARP CORNERS WITH 0.40 mm.
3. TOLERANCES WILL BE AS PER IS:6477-1983 UNLESS OTHERWISE SPECIFIED

SCALE	1:1 & 4:1
AREA mm ²	398.192
PERIMETER mm.	456.114
WEIGHT kg/m	1.075

PARTY'S NAME	GENERAL CATEGORY
PARTY'S DRAWING No.	-
ALLOY & TEMPER	HE9 WP
DESCRIPTION	WINDOW SECTION

DRAWING No.	SECTION No.
8753	8753
12273	12273
20676	20676