

8754

12267

20677

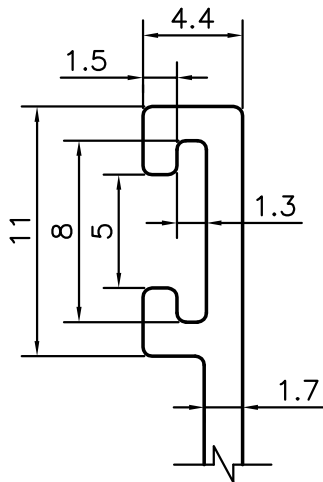

DETAIL OF "A"
SCALE 3:1

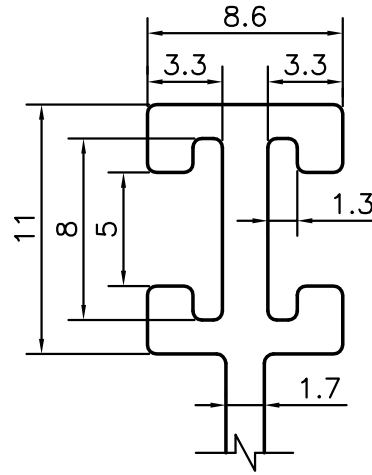

DETAIL OF "A"
SCALE 3:1

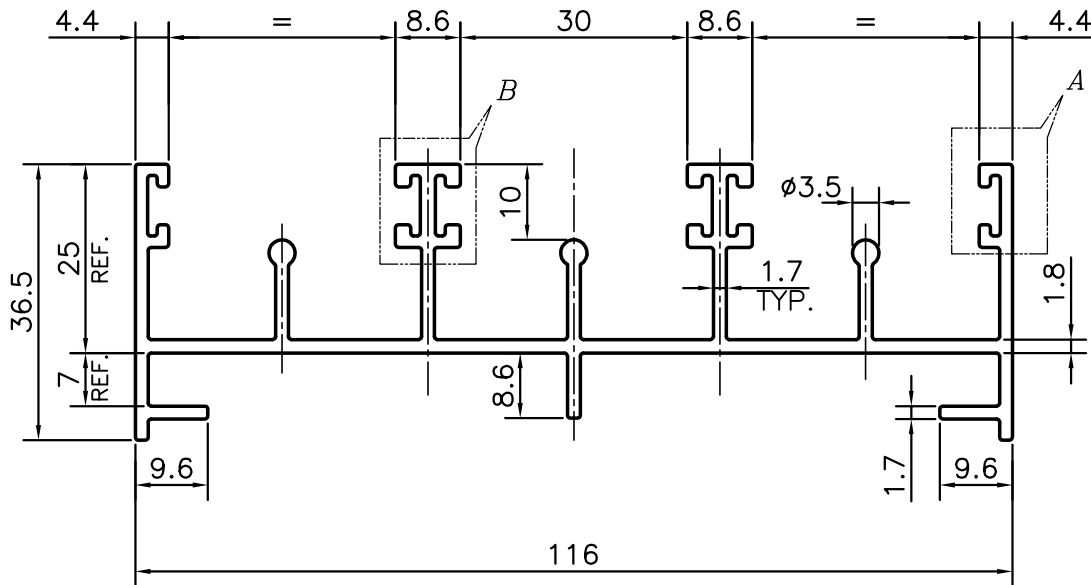

SYMBOL OF QUALITY
AN ISO 9001 COMPANY

JINDAL ALUMINIUM LTD.
BANGALORE-560073 (INDIA)

	NAME	DATE
DRAWN	PARVESH	25-05-2013
CHECKED		
APPROVED	S.S.GARG	25-05-2013

1. ALL DIMENSIONS ARE IN mm.
2. ROUND OFF ALL SHARP CORNERS WITH 0.40 mm.
3. TOLERANCES WILL BE AS PER IS:3965-1981, UNLESS OTHERWISE SPECIFIED

SCALE	1:1
AREA mm ²	620.0
PERIMETER mm.	693.108
WEIGHT kg/m	1.674

PARTY'S NAME	-
PARTY'S DRAWING No.	-
ALLOY & TEMPER	HE9 WP
DESCRIPTION	WINDOW SECTION - 3 TRACK BOTTOM

DRAWING No.	SECTION No.
8754	8754
12267	12267
20677	20677