

8755

12268

20678

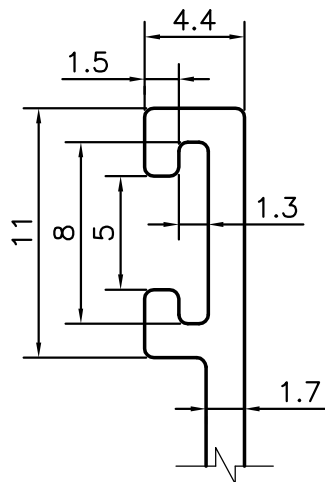

DETAIL OF "A"
SCALE 3:1

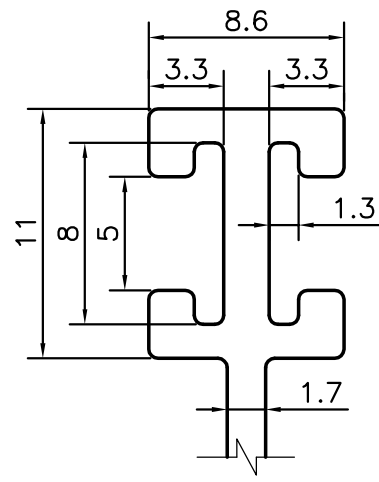

DETAIL OF "A"
SCALE 3:1

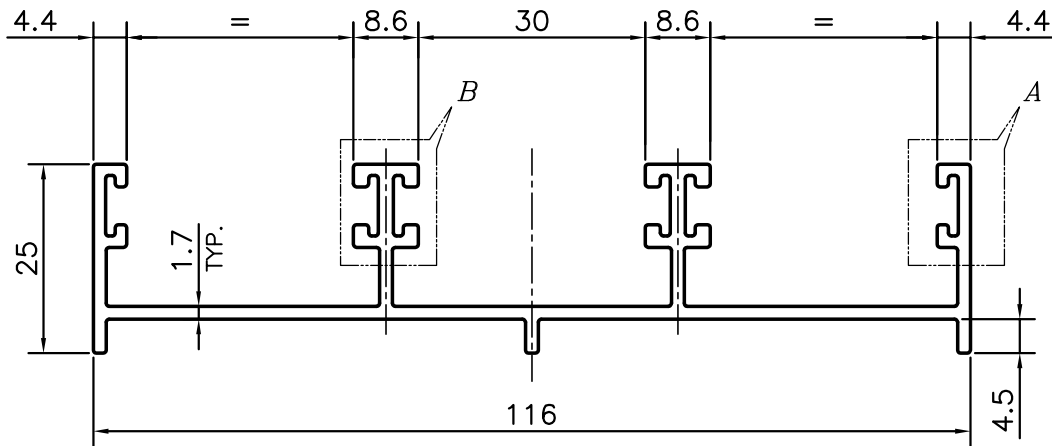

SYMBOL OF QUALITY
AN ISO 9001 COMPANY

JINDAL ALUMINIUM LTD.
BANGALORE-560073 (INDIA)

| | NAME | DATE |
|----------|----------|------------|
| DRAWN | PARVESH | 23-05-2013 |
| CHECKED | | |
| APPROVED | S.S.GARG | 23-05-2013 |

1. ALL DIMENSIONS ARE IN mm.
2. ROUND OFF ALL SHARP CORNERS WITH 0.40 mm.
3. TOLERANCES WILL BE AS PER IS:3965-1981, UNLESS OTHERWISE SPECIFIED

| | |
|----------------------|---------|
| SCALE | 1:1 |
| AREA mm ² | 442.222 |
| PERIMETER mm. | 510.379 |
| WEIGHT kg/m | 1.194 |

| PARTY'S NAME | - | DRAWING No. | SECTION No. |
|---------------------|------------------------------|-------------|-------------|
| PARTY'S DRAWING No. | - | 8755 | 8755 |
| ALLOY & TEMPER | HE9 WP | 12268 | 12268 |
| | | 20678 | 20678 |
| DESCRIPTION | WINDOW SECTION - 3 TRACK TOP | | |