

8782

12053

20702

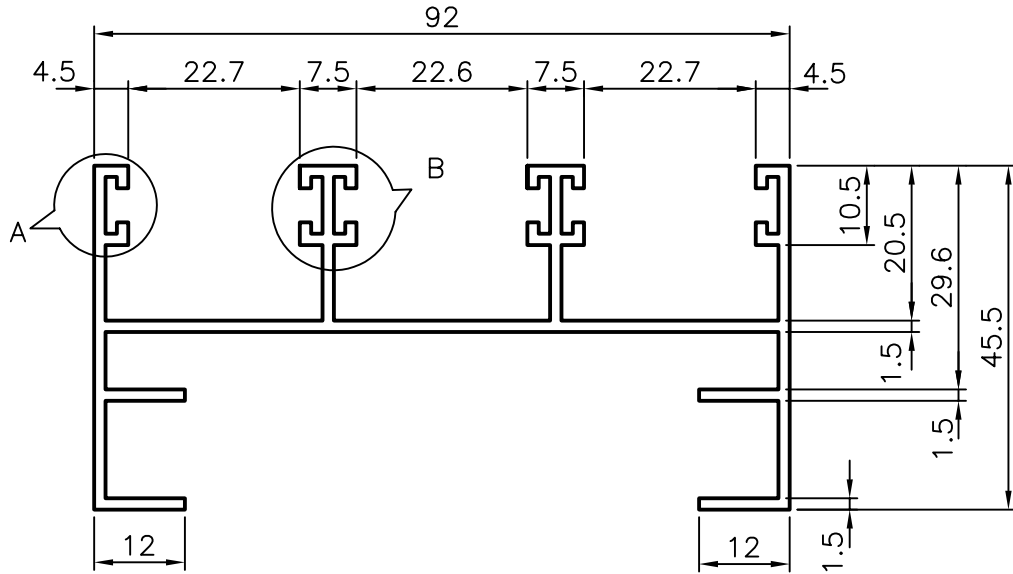

GEN. WALL THICKNESS:-1.5mm

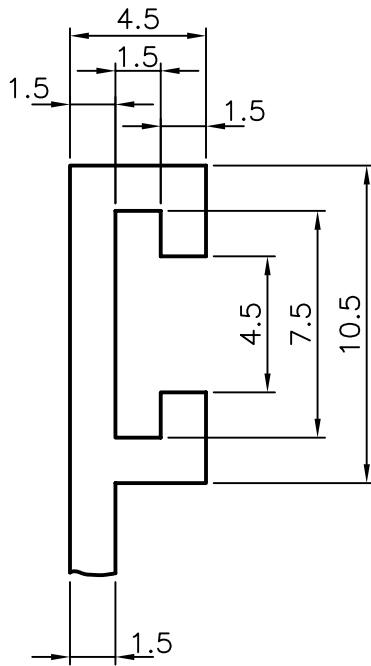

DETAIL AT 'A'

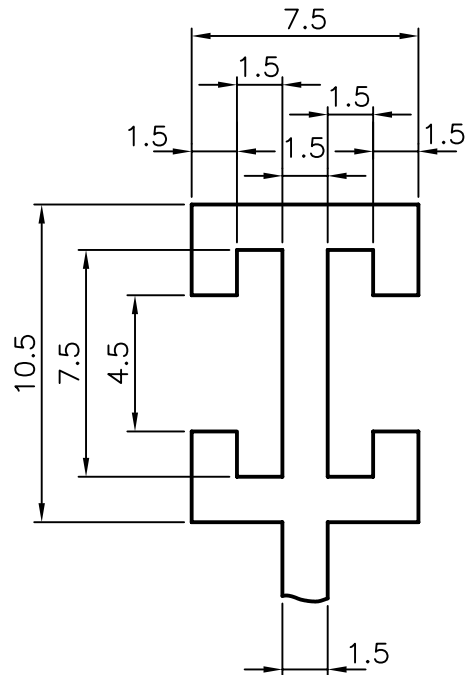

DETAIL AT 'B'

1. WALL THICKNESS SHOULD NOT BE LESS THAN 1.5 mm
2. WEIGHT SHOULD NOT BE LESS THAN 1.198 Kg/m.



SYMBOL OF QUALITY
AN ISO 9002 COMPANY

JINDAL ALUMINIUM LTD.
BANGALORE-560073 (INDIA)

1. ALL DIMENSIONS ARE IN mm.
2. ROUND OFF SHARP CORNERS WITH 0.4mm R.
3. TOLERANCES WILL BE AS PER IS: 3965-1981

PARTY'S NAME

-

PARTY'S DRAWING No.

-

FINISH

-

ALLOY & TEMPER

HE 9 WP

LENGTH:

3658mm

DESCRIPTION

WINDOW SECTION

NAME

DATE

DRAWN

R.D.SHARMA

CHECKED

APPROVED

SCALE

1:1 & 4:1

WEIGHT kg/m

1.284

SECTION No.

20702

DRAWING No.

20702