

8788

12255

20707

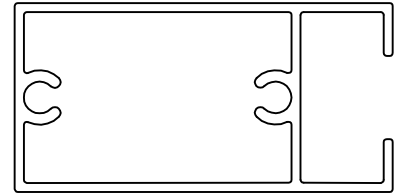

1:1

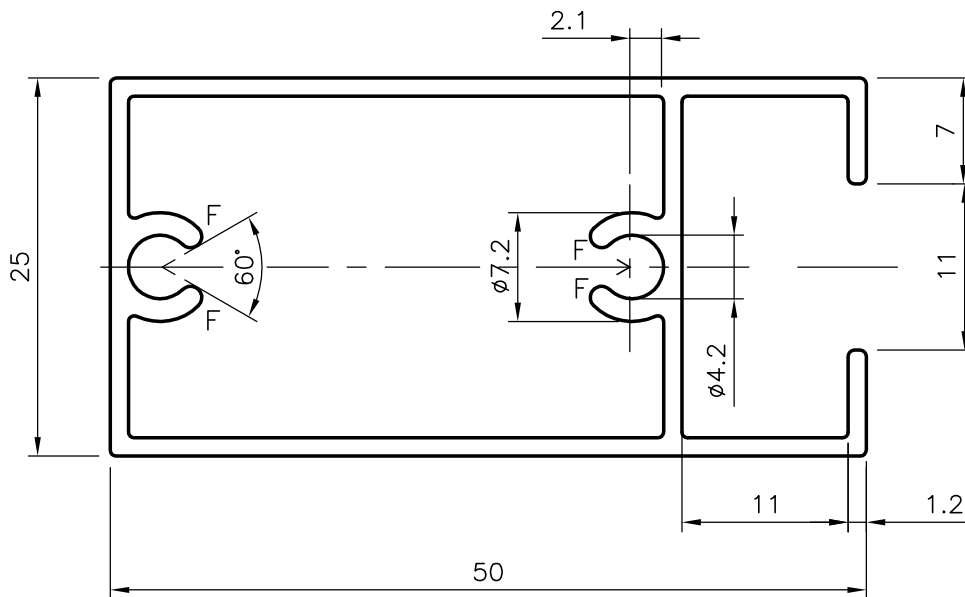

GENERAL WALL THICKNESS = 1.20 mm.

F = FULL RADII (4 PLACE)

3658 mm. LONG PIECES IN 100kgs :- 46 (AVERAGE)

SYMBOL OF QUALITY
AN ISO 9001 COMPANY**JINDAL ALUMINIUM LTD.**
BANGALORE-560073 (INDIA)

	NAME	DATE
DRAWN	D K Shaw	04-11-03
CHECKED		
APPROVED		

1. ALL DIMENSIONS ARE IN mm.
2. ROUND OFF ALL SHARP CORNERS WITH 0.40 mm.
3. TOLERANCES WILL BE AS PER IS: 6477-1983 UNLESS OTHERWISE SPECIFIED

SCALE	2:1
AREA mm ²	220
PERIMETER mm.	195.8
WEIGHT kg/m	0.593

PARTY'S NAME	-	DRAWING No.	8788	SECTION No.	8788
PARTY'S DRAWING No.	-		12255		12255
ALLOY & TEMPER	HE9 WP		20707		20707
DESCRIPTION	WINDOW SECTION				