

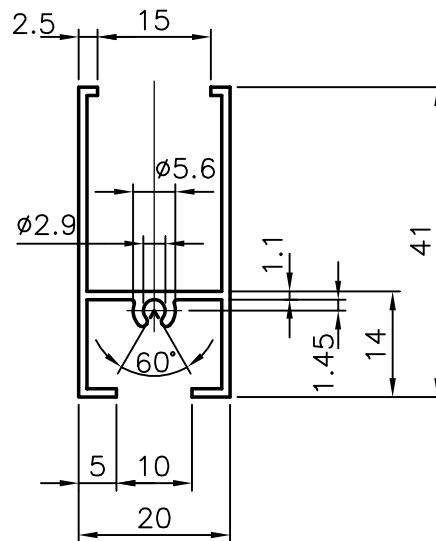

8792

12222

20710



GENERAL WALL THICKNESS : 1.10 mm

 SYMBOL OF QUALITY AN ISO 9002 COMPANY	<b>JINDAL ALUMINIUM LTD.</b> <b>BANGALORE-560073 (INDIA)</b>		NAME	DATE
			DRAWN	R.D.SHARMA 23.2.90
1. All dimensions are in mm. 2. Round off all sharp corners with 0.4mm R. 3. Tolerances will be as per IS: 3965-1981.			CHECKED	
			APPROVED	
			SCALE	1:1
PARTY'S NAME			WEIGHT kg/m	0.355
PARTY'S DRAWING No.			SECTION No.	<del>20710</del> 20710
ALLOY & TEMPER	HE9WP	LENGTH: 3658mm.	DRAWING No.	
DESCRIPTION	WINDOW SECTION		<del>20710</del> 20710	