

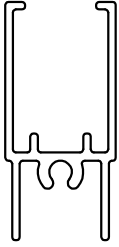

8801
11874
20718

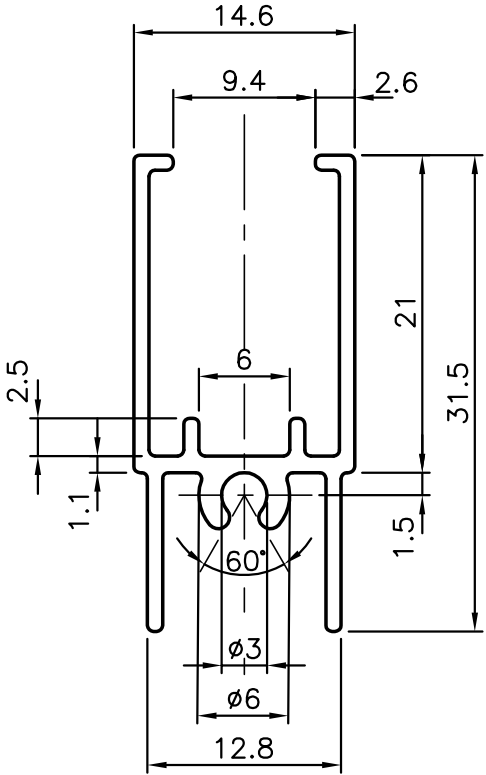

1:1



1. GENERAL WALL THICKNESS:-1.0mm  
 2. 104 PCS. REQD. IN 100 KGS.

 SYMBOL OF QUALITY AN ISO 9002 COMPANY	<b>JINDAL ALUMINIUM LTD.</b> BANGALORE-560073 (INDIA)			NAME	DATE
				DRAWN	R.D.SHARMA
1. ALL DIMENSIONS ARE IN mm. 2. ROUND OFF SHARP CORNERS WITH 0.4mm R. 3. TOLERANCES WILL BE AS PER IS: 3965-1981.				CHECKED	
				APPROVED	
				SCALE	2:1
PARTY'S NAME	-			WEIGHT kg/m	0.263
PARTY'S DRAWING No.	-	FINISH	-	SECTION No.	20718
ALLOY & TEMPER	HE9 WP	LENGTH:	3658mm	DRAWING No.	
DESCRIPTION	WINDOW SECTION			20718	