

8819

12492

20735

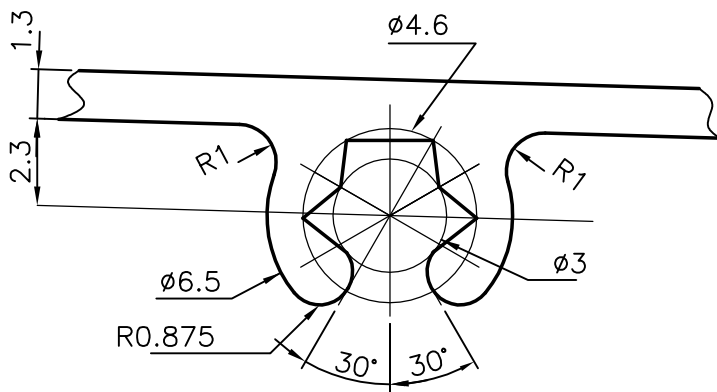

DETAIL OF 'A'

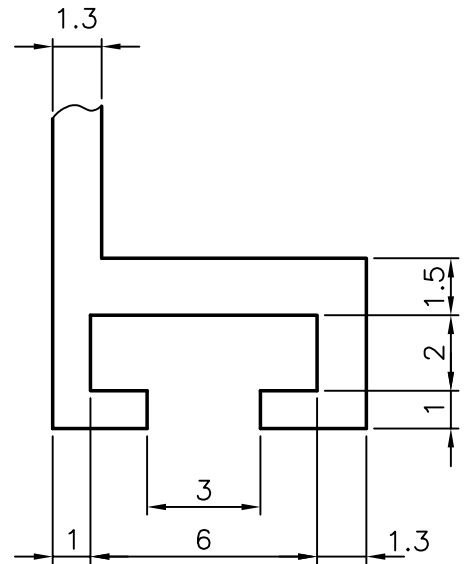

DETAIL OF 'B'

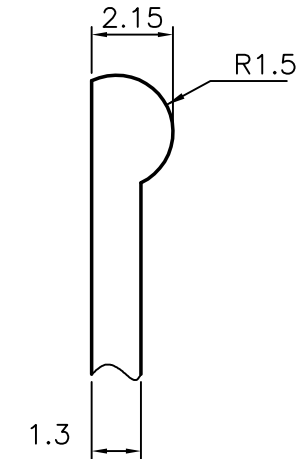
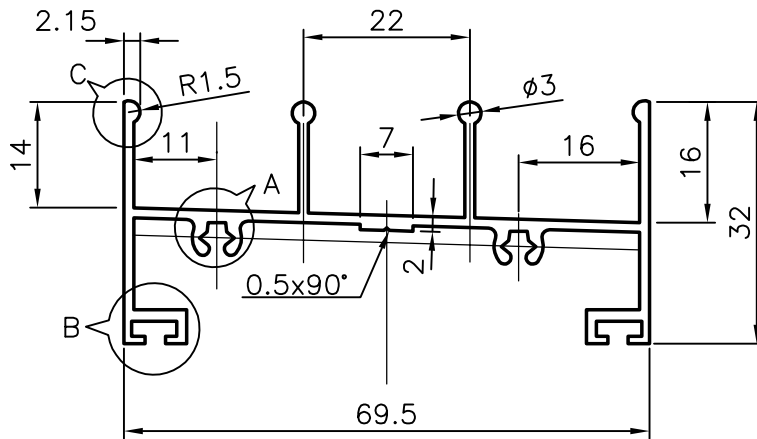

DETAIL OF 'C'

TYP. WALL THICKNESS : 1.3 ^{+0.3}/_{-0.0}



SYMBOL OF QUALITY
AN ISO 9002 COMPANY

JINDAL ALUMINIUM LTD.
BANGALORE-560073 (INDIA)

	NAME	DATE
DRAWN	R.D.Sharma	20.12.90
CHECKED		
APPROVED		
SCALE	1:1 & 5:1	
WEIGHT kg/m	0.793	
SECTION No.	20735	
DRAWING No.	20735	

1. All dimensions are in mm. 2. Round off all sharp corners with 0.4mm R. 3. Tolerances will be as per IS: 3965-1981, Unless otherwise specified.			
PARTY'S NAME	AJIT INDIA (MADRAS)PVT.LTD., MADRAS.		
PARTY'S DRAWING No.	5107 (REV.-1)	FINISH	
ALLOY & TEMPER	HE 9 WP	LENGTH:	AS PER REQUIREMENT
DESCRIPTION	WINDOW SECTION		