

8829

20743

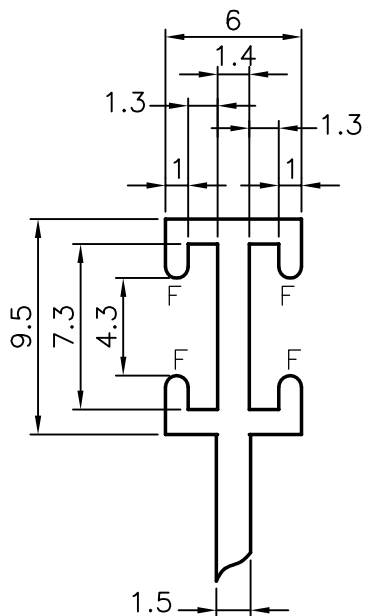

DETAIL AT 'B'

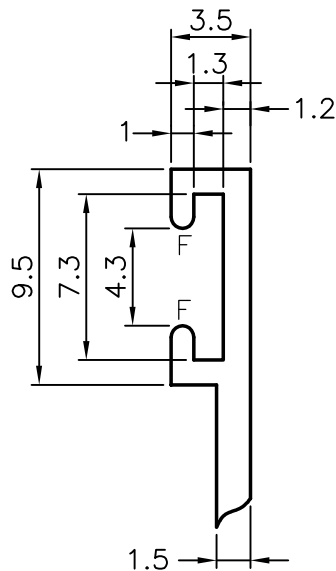

DETAIL AT 'A' (TYP.)

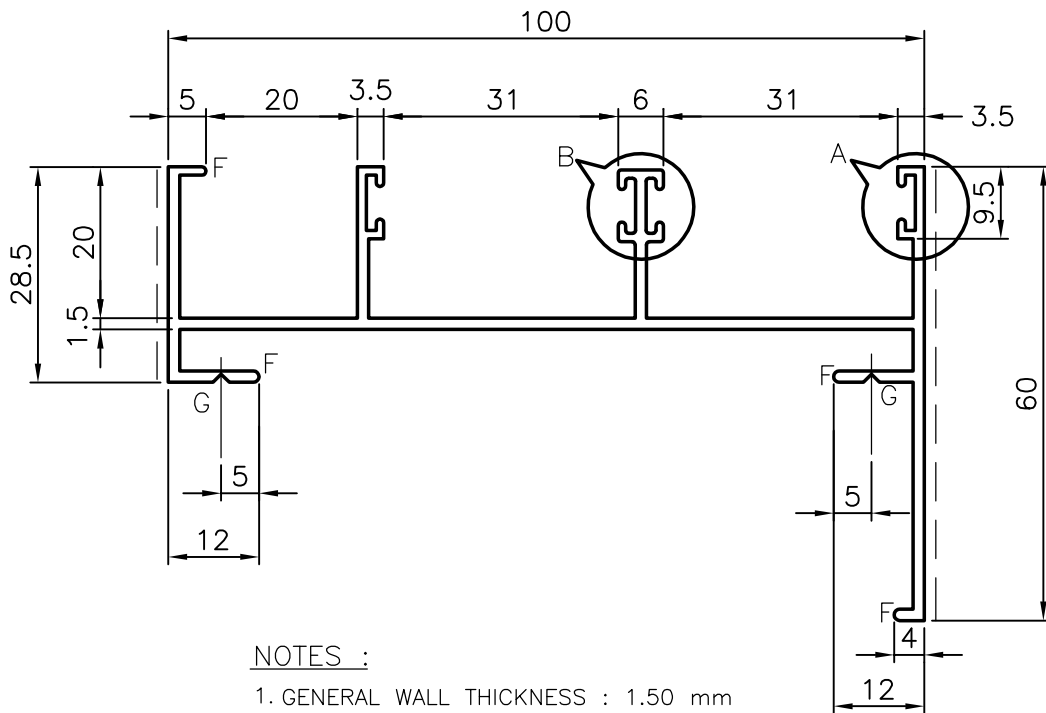

NOTES :

1. GENERAL WALL THICKNESS : 1.50 mm
2. F - FULL RADIUS (12)
3. G - GROOVE 0.50 X 90° (2)
4. ----- EXPOSED SURFACE



SYMBOL OF QUALITY
AN ISO 9001 COMPANY

JINDAL ALUMINIUM LTD.
BANGALORE-560073 (INDIA)

	NAME	DATE
DRAWN	MALINGAPPA	12-09-2005
CHECKED		
APPROVED		

1. ALL DIMENSIONS ARE IN mm.
2. ROUND OFF ALL SHARP CORNERS WITH 0.40 mm.
3. TOLERANCES WILL BE AS PER IS:3965-1981 UNLESS OTHERWISE SPECIFIED

SCALE	1:1&3:1
AREA mm ²	398.583
PERIMETER mm.	560.117
WEIGHT kg/m	1.088

PARTY'S NAME WHITE ALUMINIUM EST.,ABU DHABI

PARTY'S DRAWING No. PD 91447

ALLOY & TEMPER HE9 WP

DESCRIPTION WINDOW SECTION

DRAWING No.	SECTION No.
8829	8829
20743	20743