

DETAIL AT 'A' (TYP.)

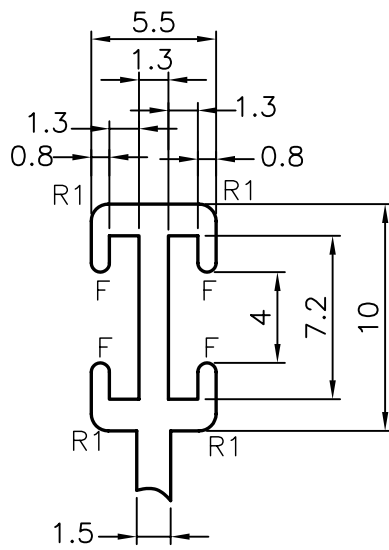

DETAIL AT 'B'

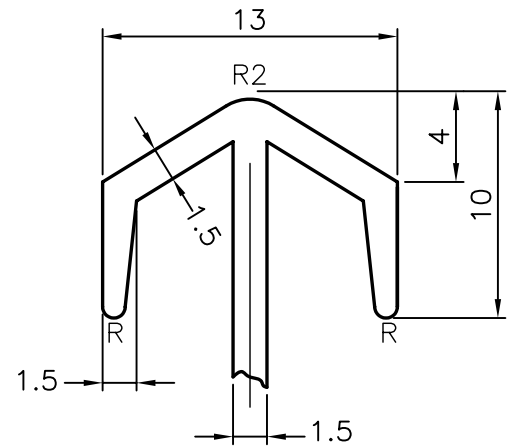

DETAIL AT 'C' (TYP.)

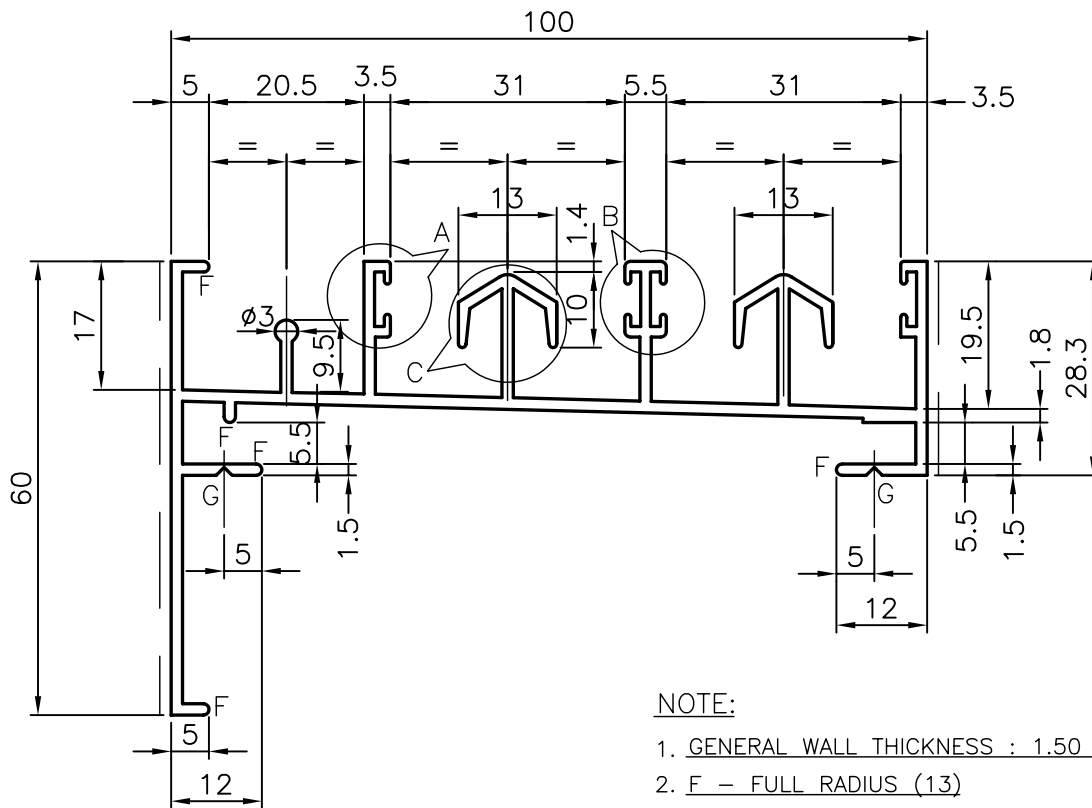

NOTE:

1. GENERAL WALL THICKNESS : 1.50 mm
2. F - FULL RADIUS (13)
3. G - GROOVE 0.50 X 90° (2)
4. R - 0.50 RADIUS (4)
5. R1 - 0.75 RADIUS (8)
6. R2 - 2.00 RADIUS (2)
7. ----- EXPOSED SURFACE

20744
8830

 SYMBOL OF QUALITY AN ISO 9002 COMPANY	JINDAL ALUMINIUM LTD. BANGALORE-560073 (INDIA)		NAME	DATE
			DRAWN	R.D.SHARMA 6.8.93
1. All dimensions are in mm. 2. Round off all sharp corners with 0.4R. 3. Tolerances will be as per IS: 3965-1981			CHECKED	
			APPROVED	
			SCALE	1:1 & 3:1
PARTY'S NAME	WHITE ALUMINIUM EST., ABU DHABI	WEIGHT kg/m	1.476	
PARTY'S DRAWING No.	PD 91448	SECTION No.	8830 20744	
ALLOY & TEMPER	HE 9 WP	LENGTH: 5970 mm.	DRAWING No.	
DESCRIPTION	WINDOW SECTION		8830 20744	