

8832  
12493  
20745

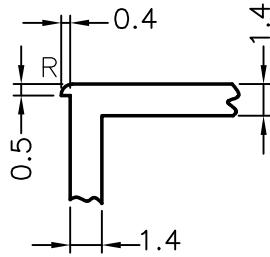

DETAIL AT 'A'

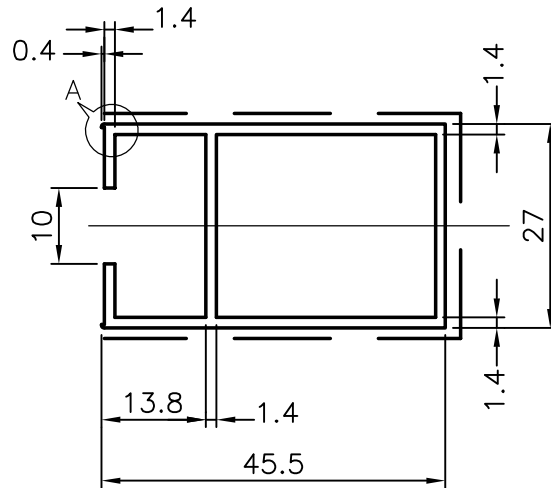

NOTE:

1. GENERAL WALL THICKNESS : 1.40 mm.
2. R - 0.50 RADIUS (2)
3. ----- EXPOSED SURFACE

|                                                                                                                                 |                                                                 |                  |                       |         |
|---------------------------------------------------------------------------------------------------------------------------------|-----------------------------------------------------------------|------------------|-----------------------|---------|
| <br>SYMBOL OF QUALITY<br>AN ISO 9002 COMPANY | <b>JINDAL ALUMINIUM LTD.</b><br><b>BANGALORE-560073 (INDIA)</b> |                  | NAME                  | DATE    |
|                                                                                                                                 |                                                                 | DRAWN            | R.D.SHARMA            | 30.7.93 |
| 1. All dimensions are in mm.<br>2. Round off all sharp corners with 0.4R.<br>3. Tolerances will be as per IS: 6477-1983         |                                                                 | CHECKED          |                       |         |
|                                                                                                                                 |                                                                 | APPROVED         |                       |         |
|                                                                                                                                 |                                                                 | SCALE            | 1:1 & 3:1             |         |
| PARTY'S NAME                                                                                                                    | WHITE ALUMINIUM EST.,<br>ABU DHABI                              | WEIGHT kg/m      | 0.578                 |         |
| PARTY'S DRAWING No.                                                                                                             | PD 91455                                                        | SECTION No.      | <del>8832</del> 20745 |         |
| ALLOY & TEMPER                                                                                                                  | HE 9 WP                                                         | LENGTH: 5970 mm. | DRAWING No.           |         |
| DESCRIPTION                                                                                                                     | WINDOW SECTION                                                  |                  | <del>8832</del> 20745 |         |