

8833
12494
20746

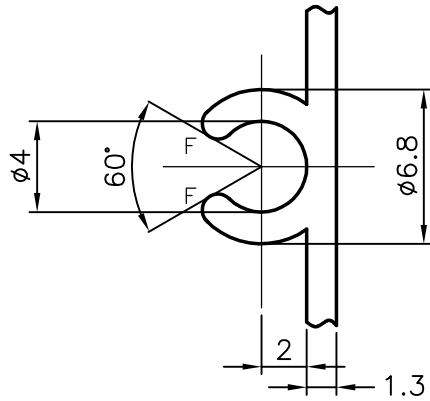

DETAIL AT 'A'

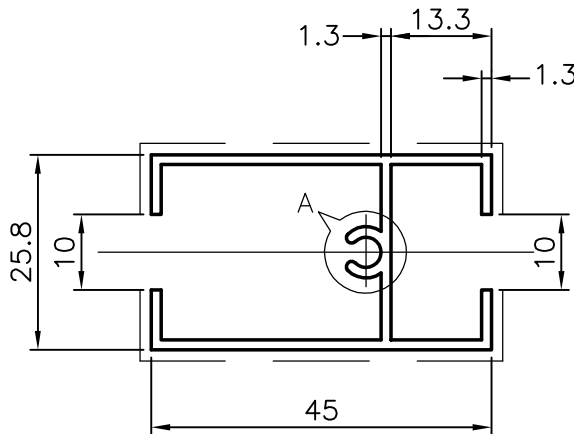

NOTE :

1. GENERAL WALL THICKNESS : 1.30 mm.
2. F – FULL RADIUS (2)
3. ----- EXPOSED SURFACE

 SYMBOL OF QUALITY AN ISO 9002 COMPANY	JINDAL ALUMINIUM LTD. BANGALORE-560073 (INDIA)		NAME	DATE
			DRAWN	R.D.SHARMA 31.7.93
1. All dimensions are in mm. 2. Round off all sharp corners with 0.4mm R. 3. Tolerances will be as per IS: 3965-1981			CHECKED	
			APPROVED	
			SCALE	1:1 & 3:1
PARTY'S NAME	WHITE ALUMINIUM EST., ABU DHABI		WEIGHT kg/m	0.529
PARTY'S DRAWING No.	G 9041 80-12-16		SECTION No.	8833 20746
ALLOY & TEMPER	HE 9 WP	LENGTH: 5970 mm.	DRAWING No.	
DESCRIPTION	WINDOW SECTION		8833 20746	