

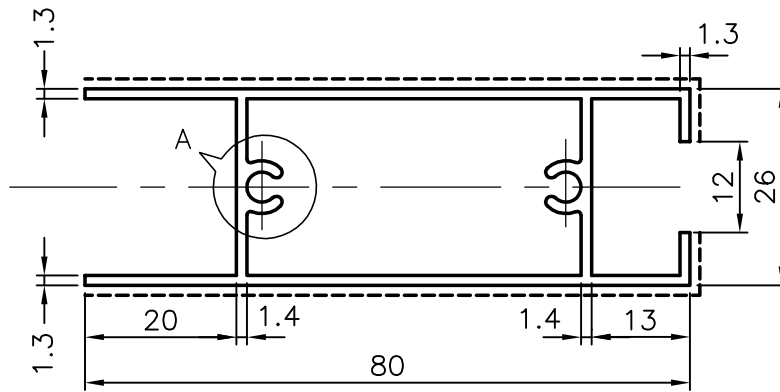

8836  
20749

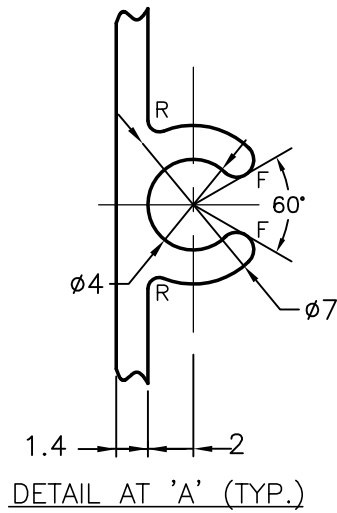

NOTE:

1. F - FULL RADIUS (4)
2. R - 0.50 RADIUS (4)
3. ----- EXPOSED SURFACE

 SYMBOL OF QUALITY AN ISO 9002 COMPANY	<b>JINDAL ALUMINIUM LTD.</b> <b>BANGALORE-560073 (INDIA)</b>		NAME	DATE
			DRAWN	R.D.SHARMA 30.7.93
1. All dimensions are in mm. 2. Round off all sharp corners with 0.4R. 3. Tolerances will be as per IS: 6477-1983			CHECKED	
			APPROVED	
			SCALE	1:1 & 3:1
PARTY'S NAME	WHITE ALUMINIUM EST., ABU DHABI	WEIGHT kg/m	0.867	
PARTY'S DRAWING No.	90-5-57	SECTION No.	<del>8836</del> 20749	
ALLOY & TEMPER	HE9WP	LENGTH: 5970 mm.	DRAWING No.	
DESCRIPTION	WINDOW SECTION		<del>8836</del> 20749	