

8849

12498

20757

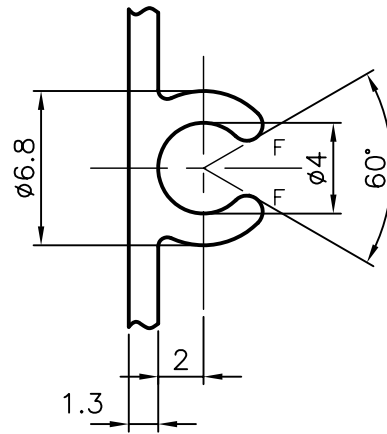

DETAIL AT 'A' (TYP.)
SCALE 3:1

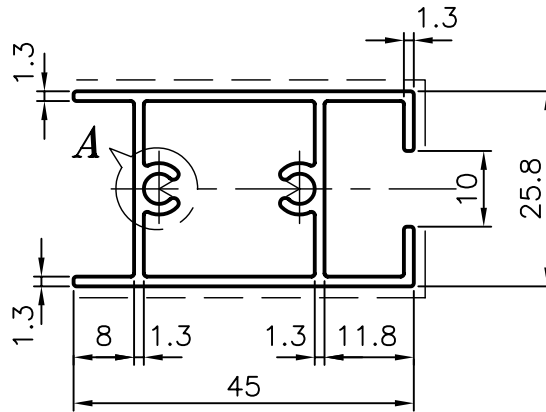

NOTES:—

1. ----- EXPOSED SURFACE
2. F – FULL RADIUS (4)
3. GENERAL WALL THICKNESS : 1.30 mm.



SYMBOL OF QUALITY
AN ISO 9001 COMPANY

JINDAL ALUMINIUM LTD.
BANGALORE-560073 (INDIA)

	NAME	DATE
DRAWN	MALINGAPPA	01-09-2005
CHECKED		
APPROVED		
SCALE		1:1
AREA mm ²		222.811
PERIMETER mm.		204.853
WEIGHT kg/m		0.602
DRAWING No.		SECTION No.
8849		8849
12498		12498
20757		20757

1. ALL DIMENSIONS ARE IN mm.
2. ROUND OFF ALL SHARP CORNERS WITH 0.50 mm.
3. TOLERANCES WILL BE AS PER IS:6477-1983 UNLESS OTHERWISE SPECIFIED

PARTY'S NAME UNIVERSAL ALUMINUM CO., BAHRAIN

PARTY'S DRAWING No. PD 91451

ALLOY & TEMPER HE9 WP

DESCRIPTION WINDOW SECTION